

INJ. PUMP CALIBRATION DATA

ENGINE MODEL SD33

BOSCH No.9 400 610 068 1/4
 DKKC No. 101631-9775
 Date: 15, Oct. 1987 5
 Company: NISSAN DIESEL
 No. 16700 C8605

101631-9775 2/4

Injection pump: PES6A Governor: EP/RBD Timing device: EP/SCD
 101063-9371 105542-4271 105622-1100

1. Test Conditions:

Pump rotation: clockwise viewed from drive side
 Nozzle & Nozzle Holder Ass'y: 105780-8140 Nozzle Holder: 105780-2080
 (BOSCH Type No. EF8511/9A) (BOSCH Type No. EF8511/9)
 Nozzle opening pressure: 175 kg/cm² Transfer pump pressure: 1.6 kg/cm²
 Injection pipe: Inner Dia. 2 mm x Outer Dia. 6 mm - Length 600 mm
 Test Oil: ISO4113 or SAE Standard Test Oil (SAE J967d) Oil Temp.: 40 +5°C
 Overflow valve opening pressure: -- kg/cm² (Part No. ----)

2. Injection Timing:

Pre-stroke: No. 1 Plunger 2.0 ±0.05 mm
 Note: Adjust with control rod position of ---- mm
 Injection order: 1 60°±30' 4, 1 120°±30' 2, 1 180°±30' 6, 1 240°±30' 3, 1 300°±30' 5 (interval: -- ± 30')
 Plungers are numbered from the Drive side.
 Tappet clearance: Bolt adjustment type: More than 0.3 mm for all cylinders.
 Shim adjustment type: Manually rotate the camshaft 2 - 3 times and confirm that it rotates smoothly.

4. Injection Quantity:

Adjusting Point	Rod Position (mm)	Pump Speed (r.p.m)	Injection Q'ty (cc/1000 strokes)	Max. var bet. cyl (%)	Fixed	Remarks
	12.6	800	33.0 ~ 35.0	±2.5	Rack	Basic
	Approx. 7.8	300	6.5 ~ 8.5	±15	Rack	
	12.6	800	33.0 ~ 35.0	±2.5	Rack	
	12.3	1,900	(36.5 ~ 39.7)	±4	Rack	
	15 ± 0.1	100	(40.0)	-	Rack	Control rack limit

5. Timing Advance Specification:

Pump Speed (r.p.m)	Below 550	500	1,100	1,900
Advance Angle (deg.)	Start	Below 0.5	1.2 - 2.2	Finish 5.5 ~ 6.5

3. GOVERNOR ADJUSTMET

(1) Pneumatic Governor

(2) Mechanical Governor

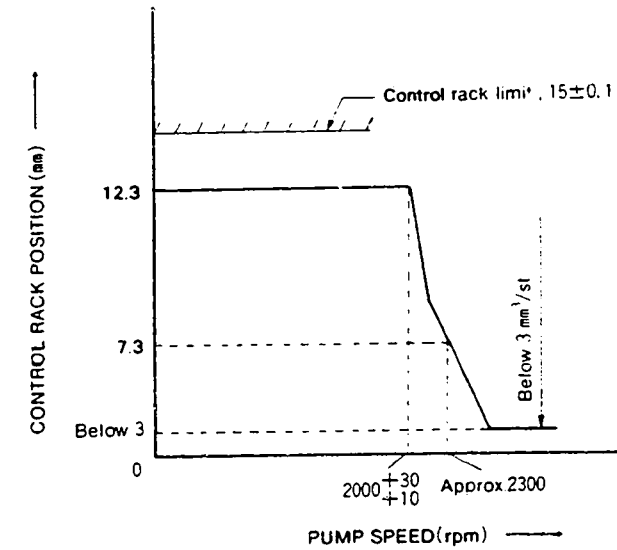
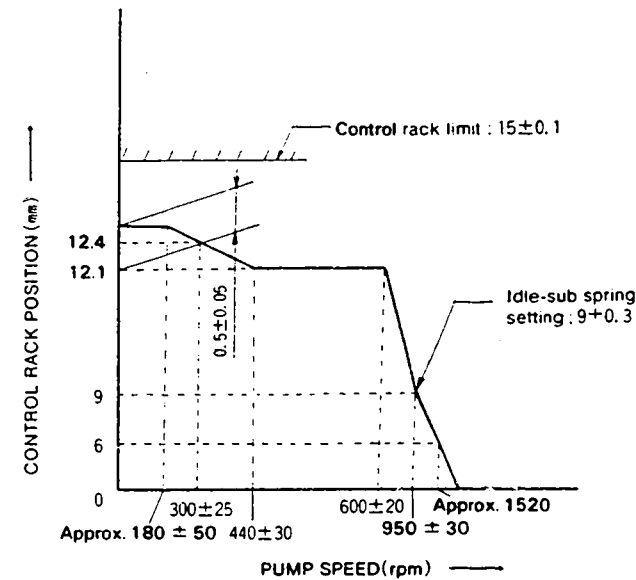

■ Air Tightness Test

- Increase the pressure of the pneumatic governor's negative pressure chamber to 500 mmAq at a pump speed of 500 rpm and a control rack position of 12.2 mm.
- Then, confirm that it takes 10 seconds or more for the negative pressure to fall from 500 mmAq to 480 mmAq.

■ Adjustment

- Pneumatic Governor (Pump Speed : 500 rpm)

Item	Negative Press. (mmAq)	Rack Position (mm)	Remarks
Smoke Set Screw Adjustment	0	12.2	• Adjust using spring capsule ①.
Torque Control Adjustment			
① Start of torque control spring movement	Approx 180	12.2	• Adjust thickness of shim ①.
② End of torque control spring movement	410~470	12.1	• Adjust thickness of shim ②.
③ Confirm	275~325	12.4	
④ Confirm torque control stroke	---	---	• Inspection : 0.5±0.05 mm

Item	Negative Press. (mmAq)	Rack Position (mm)	Remarks
High-speed Control Adjustment	580~620	12.1	• Adjust thickness of shim ③.
Idling Adjustment	870~930 Approx 1470	9+0.3 6	• Adjust using spring capsule ②. • Confirm

2. Mechanical Governor (Negative pressure: 370±20 mmAq)

Item	Pump Speed (rpm)	Rack Position (mm)	Remarks
Maximum Speed Control Adjustment	2010~2030 Approx 2300	12.3 7.3	• Adjust using screw ①. • Confirm • Confirm (Check the fuel injection quantity: below 3 cc/1000st)

■ Timing Setting

At No.1 plunger's beginning of injection position.

B.T.D.C. : 20°

Pump center line

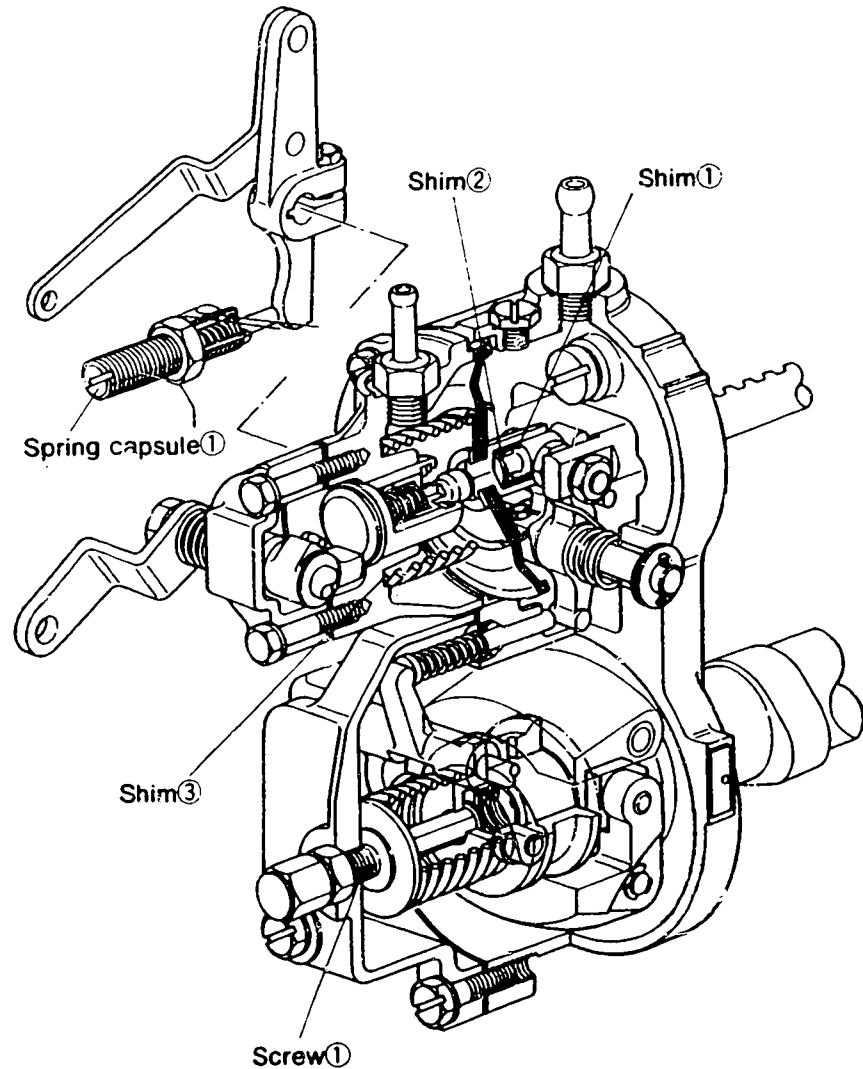
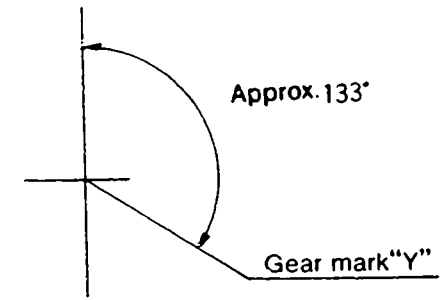

INJ. PUMP CALIBRATION DATA

ENGINE MODEL SD33T

BOSCH No.9 400 610 063 1/5
 DKKC No. 101641-9123
 Date: 15, Oct 1987
 Company: NISSAN DIESEL
 No. 16700 C8700

Injection pump: PES6A Governor: EP/RLD Timing device: EP/SCD
 101064-9050 105931-1522 105622-1120

1. Test Conditions:

Pump rotation: clockwise viewed from drive side
 Nozzle & Nozzle Holder Ass'y: 105780-8140 Nozzle Holder: 105780-2080
 (BOSCH Type No. EF8511/9A) (BOSCH Type No. EF8511/9)
 Nozzle opening pressure: 175 kg/cm² Transfer pump pressure: 1.6 kg/cm²
 Injection pipe: Inner Dia. 2 mm x Outer Dia. 6 mm -- Length 600 mm
 Test Oil: ISO4113 or SAE Standard Test Oil (SAE J967d) Oil Temp.: 40 +5°C
 Overflow valve opening pressure: -- kg/cm² (Part No. -- -- --)

2. Injection Timing:

Pre-stroke: No. 1 Plunger 2.3 ± 0.05 mm
 Note: Adjust with control rod position of -- -- -- mm
 Injection order: 1 $60^\circ \pm 30'$ 4, 1 $120^\circ \pm 30'$ 2, 1 $180^\circ \pm 30'$ 6, 1 $240^\circ \pm 30'$ 3, 1 $300^\circ \pm 30'$ 5 (interval: -- ± 30')
 Plungers are numbered from the Drive side.
 Tappet clearance: Bolt adjustment type: More than 0.3 mm for all cylinders.
 Shim adjustment type: Manually rotate the camshaft 2 - 3 times and confirm that it rotates smoothly.

4. Injection Quantity:

Adjusting Point	Rod Position (mm)	Pump Speed (r.p.m)	Injection Q'ty (cc/1000 strokes)	Max. var bet. cyl (%)	Fixed	Remarks
A	13.7	1,000	47.2 ~ 49.4	±2	Rack	Basic
H	Approx. 9.9	360	6.4 ~ 8.6	±15	Rack	
A	R ₁ (13.7)	1,000	47.2 ~ 49.4	-	Lever	Basic Boost press. Above 400 mmHg
B	R ₁ -0.7	2,000	45.2 ~ 49.2	-	Lever	Boost press. Above 400 mmHg
C	R ₂ (12.7)	500	32.6 ~ 36.6	-	Lever	Boost press. 0
I	(15.8)	100	57.0 ~ 67.0	-	Lever	Control rack limit

5. Timing Advance Specification:

Pump Speed (r.p.m)	Below 550	500	1,200	1,900
Advance Angle (deg.)	Start	Below 0.5	1.7 ~ 2.7	Finish 5.5 ~ 6.5

3. GOVERNOR ADJUSTMENT

101641-9123 2/5

CONTROL LEVER ANGLE

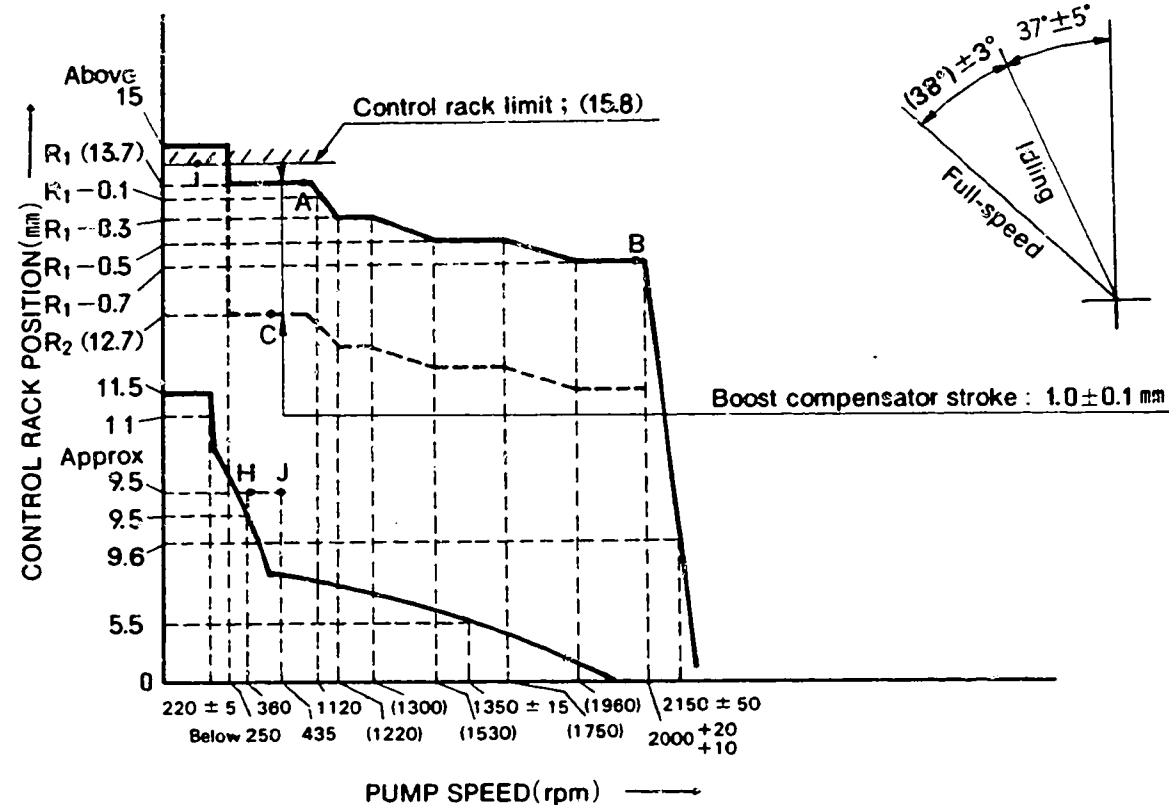

Idling Adjustment

Item	Pump Speed (rpm)	Rack Position (mm)	Remarks
Idling Lever Position: Temporary Setting	80~100	11.5	• Adjust using screw ①.
Idling Position Setting	360 215~225	9.5 11	• Adjust using spring capsule ①.
Governor Spring Contact Adjustment	1335 ~ 1365	5.5	• Adjust the governor shaft position. • Confirm
Setting the Idling Lever Position	360	Approx. 9.5	• Adjust using screw ①. • Confirm the control lever angle (32°~42°)

■ Full Load Adjustment (Torque Cam No. 74)

Item	Pump Speed (rpm)	Rack Position (mm)	Remarks
Full Speed Lever Position: Temporary Setting	Approx.2000	(13.7) - 0.7	• Adjust using screw ③. (Do not enter governor control range)
Full Load Position Adjustment	1000	13.7	• Adjust using screw ④.
Torque Cam Position Adjustment	1120	(13.7) - 0.1	• Adjust using screw ⑤.
	(1220)	(13.7) - 0.3	• Confirm
	(1300)	(13.7) - 0.3	• "
	(1530)	(13.7) - 0.5	• "
	(1750)	(13.7) - 0.5	• "
	(1960)	(13.7) - 0.7	• "
	—	—	• "
Confirm injection quantity at points A to B.			
Maximum Speed control Adjustment	2010 ~ 2020	(1.37) - 0.7	• Adjust using screw ③.
	2100 ~ 2200	9.6	• Confirm
	—	—	• After adjustment, confirm that the control lever angle is 40°~46°
Confirming Excess Fuel Limit for Engine Starting	435	Approx.9.5	• Set the control lever at point J.
	0	11.5	• Confirm
	0	Above 15	• Move the control lever to the "full-speed" position and then confirm the control rack position.
Confirm the Black Smoke Limit	Fix the control lever at point H. Then, operate the pump at 250 rpm. Confirm that the control rack does not move beyond 13.7 mm. When the control lever is moved to the "full-speed" position again increase the pump speed and confirm that the control rack starts to move from a pump speed of — rpm.		
Rack Limiter Adjustment	0	(15.8)	• Fix the control rack using screw Part No. 157954-3700
	Measure the depth of the control rack cap. Then, adjust screw ⑥ so that it equals the depth of the rack cap and install the rack cap. Confirm injection quantity at point I.		

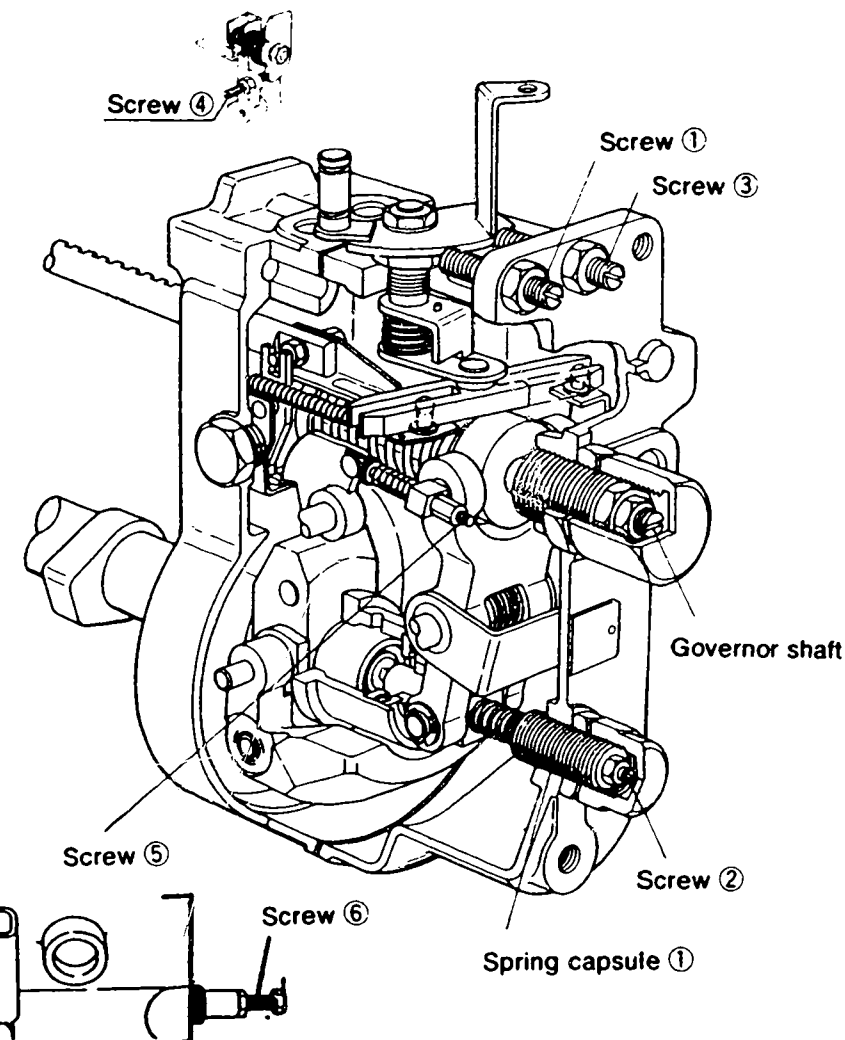

■ Boost Compensator Adjustment

- Maintain the pump speed at 700 rpm and fix the control lever in the full load position.
- In this condition, use calipers to measure the dimension "L" of the pushrod from the end face of the spacer. (Inspection: 23.9 to 24.1 mm)

Item	Pump Speed (rpm)	Rack Position (mm)	Remarks
Setting the Boost Compensator Spring Force	95~135	12.7	• Adjust using screw ⑦.
Boost Compensator Spring Adjustment (Boost compensator stroke: 1.0±0.1 mm)	0	13.7→12.7	• Adjust using screw ⑦.
	95~135	12.7	• Confirm
	300~350	13.7	• Confirm

101641-9123 5/5

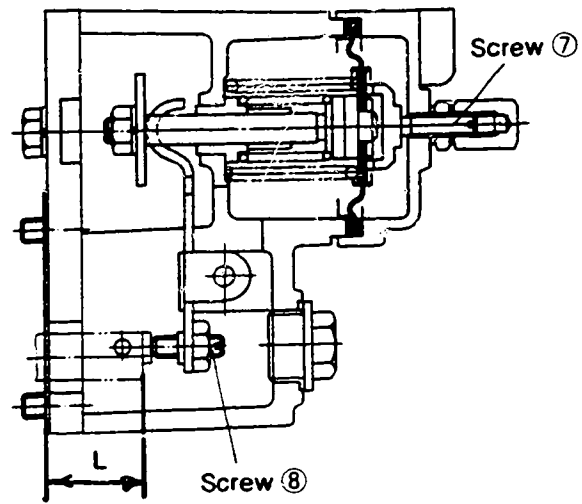
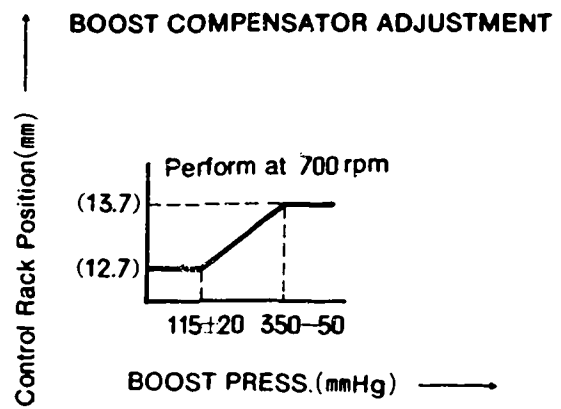

■ Timing Setting

At No. 1 plunger's beginning of injection position.

B.D.T.C. : 20

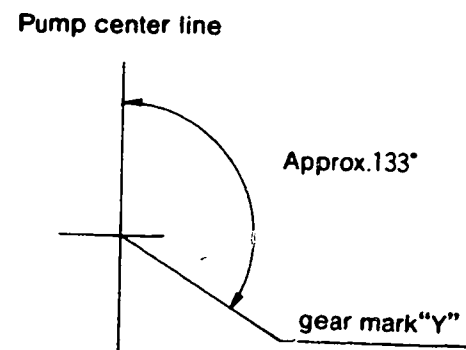

INJ. PUMP CALIBRATION DATA

ENGINE MODEL SD33T

BOSCH No.9 400 610 069 1/5
 DKKC.No. 101641-9133
 Date: 15. Oct. 1987 ④
 Company: NISSAN DIESEL
 No. 16700 C8701

Injection pump: PES6A Governor: EP/RLD Timing device: EP/SCD
 101064-9040 105931-1522 105622-1120

1. Test Conditions:

Pump rotation: clockwise viewed from drive side
 Nozzle & Nozzle Holder Ass'y: 105780-8140 Nozzle Holder: 105780-2080
 (BOSCH Type No. EF8511/9A) (BOSCH Type No. EF8511/9)
 Nozzle opening pressure: 175 kg/cm² Transfer pump pressure: 1.6 kg/cm²
 Injection pipe: Inner Dia. 2 mm x Outer Dia. 6 mm - Length 600 mm
 Test Oil: ISO4113 or SAE Standard Test Oil (SAE J967d) Oil Temp.: 40 +5°C
 Overflow valve opening pressure: -- kg/cm² (Part No. ----)

2. Injection Timing:

Pre-stroke: No. 1 Plunger 2.3 ± 0.05 mm
 Note: Adjust with control rod position of ---- mm
 Injection order: 1 $80^\circ \pm 30'$ 4, 1 $120^\circ \pm 30'$ 2, 1 $180^\circ \pm 30'$ 6, 1 $240^\circ \pm 30'$ 3, 1 $300^\circ \pm 30'$ 5 (interval: -- ± 30')
 Plungers are numbered from the Drive side.
 Tappet clearance: Bolt adjustment type: More than 0.3 mm for all cylinders.
 Shim adjustment type: Manually rotate the camshaft 2 - 3 times and confirm that it rotates smoothly.

4. Injection Quantity:

Adjusting Point	Rod Position (mm)	Pump Speed (r.p.m)	Injection Q'ty (cc/1000 strokes)	Max. var bet. cyl (%)	Fixed	Remarks
A	13.7	1,000	46.7 ~ 48.9	±2	Rack	Basic
H	Approx. 9.9	360	6.4 ~ 8.6	±15	Rack	
A	R ₁ (13.7)	1,000	46.7 ~ 48.9	-	Lever	Basic Boost press. Above 400 mmHg
B	R ₁ -0.7	2,000	46.7 ~ 50.7	-	Lever	Boost press. Above 400 mmHg
C	R ₂ (12.7)	500	33.7 ~ 37.7	-	Lever	Boost press. 0
I	(15.8)	100	57.0 ~ 67.0	-	Lever	Control rack limit

5. Timing Advance Specification:

Pump Speed (r.p.m)	Below 550	500	1,200	1,900		
Advance Angle (deg.)	Start	Below 0.5	1.7 ~ 2.7	Finish 5.5 ~ 6.5		

3. GOVERNOR ADJUSTMENT

101641-9133 2/5

CONTROL LEVER ANGLE

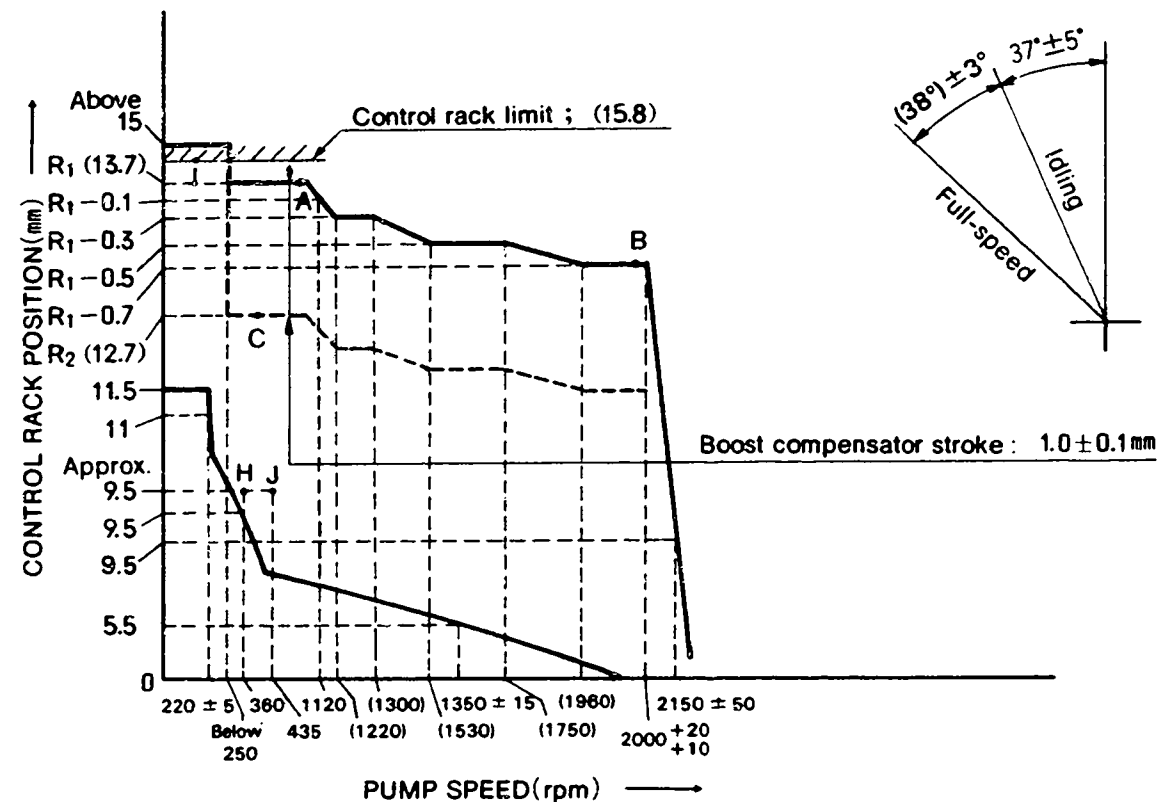

Idling Adjustment

Item	Pump Speed (rpm)	Rack Position (mm)	Remarks
Idling Lever Position: Temporary Setting	80~100	11.5	• Adjust using screw ①.
Idling Position Setting	360 215~225	9.5 11	• Adjust using spring capsule ①. • Adjust using screw ②.
Governor Spring Contact Adjustment	1335 ~ 1365	5.5	• Adjust the governor shaft position. • Confirm
Setting the Idling Lever Position	360	Approx.9.5	• Adjust using screw ①. • Confirm the control lever angle (32°~42°)

■ Full Load Adjustment (Torque Cam No. 74)

Item	Pump Speed (rpm)	Rack Position (mm)	Remarks
Full Speed Lever Position: Temporary Setting	Approx.2000	(13.7)−0.7	• Adjust using screw ③. (Do not enter governor control range)
Full Load Position Adjustment	1000	13.7	• Adjust using screw ④.
Torque Cam Position Adjustment	1120	(13.7)−0.1	• Adjust using screw ⑤.
	(1220)	(13.7)−0.3	• Confirm
	(1300)	(13.7)−0.3	• "
	(1530)	(13.7)−0.5	• "
	(1750)	(13.7)−0.5	• "
	(1960)	(13.7)−0.7	• "
	—	—	• "
Confirm injection quantity at points A to B.			
Maximum Speed control Adjustment	2010 ~ 2020	(13.7)−0.7	• Adjust using screw ③.
	2100 ~ 2200	9.5	• Confirm • After adjustment, confirm that the control lever angle is 40°~46°
Confirming Excess Fuel Limit for Engine Starting	435	Approx.9.5	• Set the control lever at point J .
	0	11.5	• Confirm
	0	Above 15	• Move the control lever to the "full-speed" position and then confirm the control rack position.
Confirm the Black Smoke Limit	Fix the control lever at point H. Then, operate the pump at 250 rpm. Confirm that the control rack does not move beyond 13.7 mm. When the control lever is moved to the "full-speed" position again increase the pump speed and confirm that the control rack starts to move from a pump speed of — rpm.		
Rack Limiter Adjustment	0	(15.8)	• Fix the control rack using screw Part No. 157954-3700
	Measure the depth of the control rack cap. Then, adjust screw ⑥ so that it equals the depth of the rack cap and install the rack cap. Confirm injection quantity at point I .		

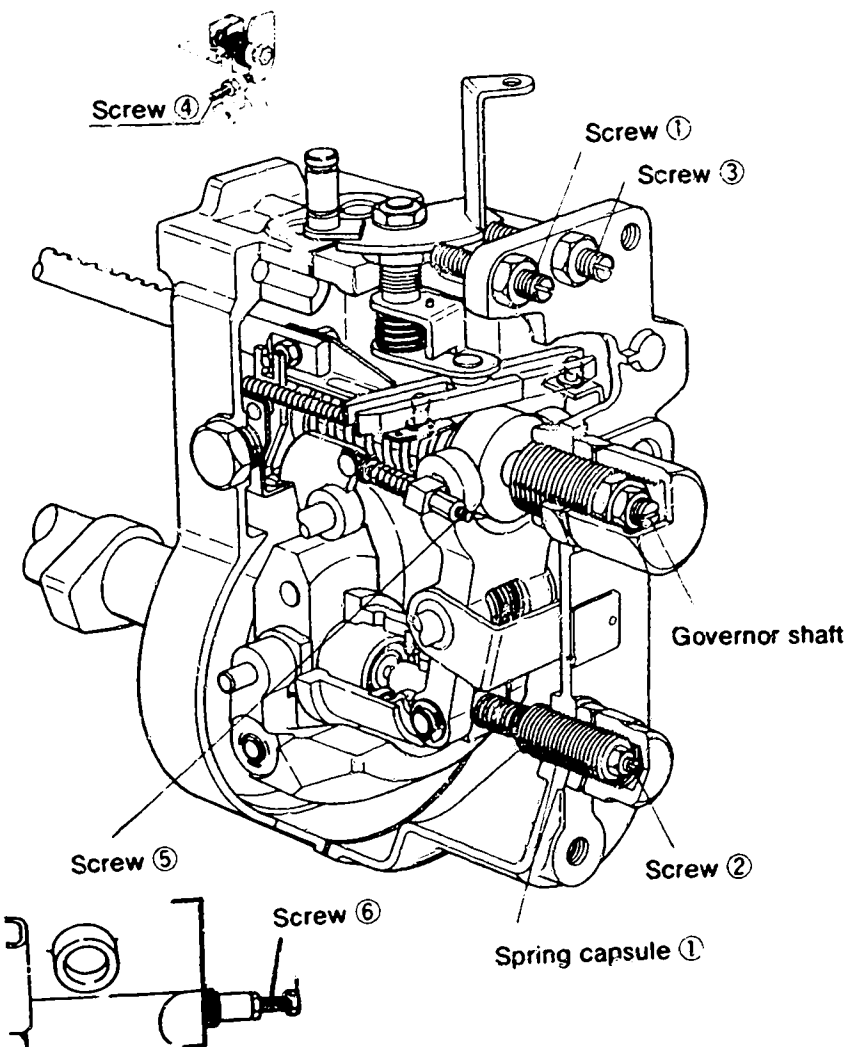

■ Boost Compensator Adjustment

- Maintain the pump speed at 700 rpm and fix the control lever in the full load position.
- In this condition, use calipers to measure the dimension "L" of the pushrod from the end face of the spacer. (Inspection: 23.9 to 24.1 mm)

Item	Pump Speed (rpm)	Rack Position (mm)	Remarks
Setting the Boost Compensator Spring Force	95~135	12.7	• Adjust using screw ⑦.
Boost Compensator Spring Adjustment (Boost compensator stroke: 1.0±0.1 mm)	⑧	13.7→12.7	• Adjust using screw ⑧.
	95~135	12.7	• Confirm
	300~350	13.7	• Confirm

101641-9133 5/5

BOOST COMPENSATOR ADJUSTMENT

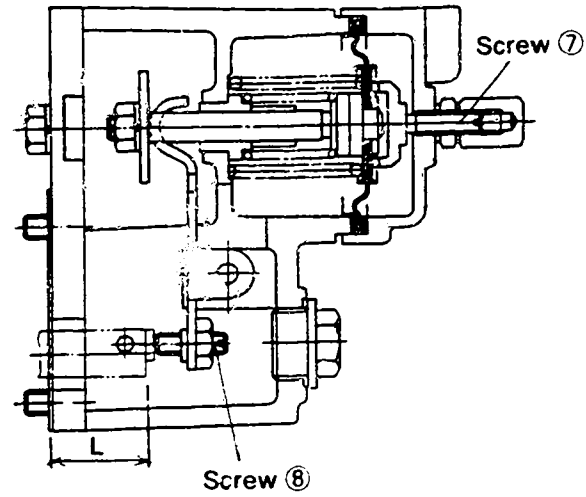
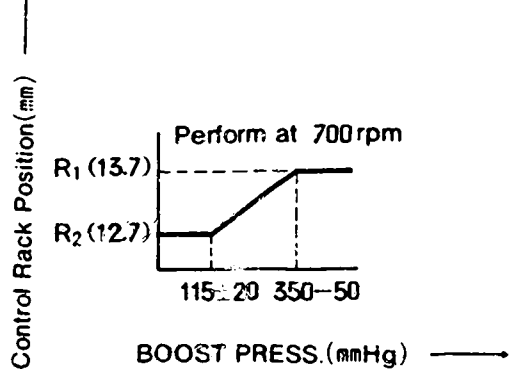

■ Timing Setting

At No. 1 plunger's beginning of injection position.

B.D.T.C. : 20°

Pump center line

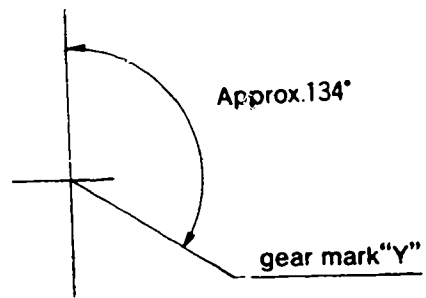

INJ. PUMP CALIBRATION DATA

ENGINE MODEL SD33T

BOSCH No. 9 400 610 070 1/5
 DKKC No. 101641-9152
 Date: 15, Oct. 1987 4
 Company: NISSAN DIESEL
 No. 16700 C8702

101641-9152 2/5

Injection pump: PES6A Governor: EP/RLD Timing device: EP/SCD
 101064-9050 105931-1522 105622-1120

1. Test Conditions:

Pump rotation: clockwise viewed from drive side
 Nozzle & Nozzle Holder Ass'y: 105780-8140 Nozzle Holder: 105780-2080
 (BOSCH Type No. EF8511/9/A) (BOSCH Type No. EF8511/9)
 Nozzle opening pressure: 175 kg/cm² Transfer pump pressure: 1.6 kg/cm²
 Injection pipe: Inner Dia. 2 mm x Outer Dia. 6 mm - Length 600 mm
 Test Oil: ISO4113 or SAE Standard Test Oil (SAE J967d) Oil Temp.: 40 ±5°C
 Overflow valve opening pressure: -- kg/cm² (Part No. ----)

2. Injection Timing:

Pre-stroke: No. 1 Plunger 2.3 ±0.05 mm
 Note: Adjust with control rod position of ---- mm
 Injection order: 1 $60^\circ \pm 30'$ 4, 1 $120^\circ \pm 30'$ 2, 1 $180^\circ \pm 30'$ 6, 1 $240^\circ \pm 30'$ 3, 1 $300^\circ \pm 30'$ 5 (interval: -- ± 30')
 Plungers are numbered from the Drive side.
 Tappet clearance: Bolt adjustment type: More than 0.3 mm for all cylinders.
 Shim adjustment type: Manually rotate the camshaft 2 - 3 times and confirm that it rotates smoothly.

4. Injection Quantity:

Adjusting Point	Rod Position (mm)	Pump Speed (r.p.m)	Injection Qty (cc/1000 strokes)	Max. var bet. cyl (%)	Fixed	Remarks
A	13.7	1,000	47.2 ~ 49.4	±2	Rack	Basic
H	Approx. 9.9	360	6.4 ~ 8.6	±15	Rack	
A	R ₁ (13.7)	1,000	47.2 ~ 49.4	-	Lever	Basic Boost press. Above 400 mmHg
B	R ₁ -0.7	2,000	45.2 ~ 49.2	-	Lever	Boost press. Above 400 mmHg
C	R ₂ (12.7)	500	32.8 ~ 36.6	-	Lever	Boost press. 0
I	(15.8)	100	57.0 ~ 67.0	-	Lever	Control rack limit

5. Timing Advance Specification:

Pump Speed (r.p.m)	Below 550	500	1,200	1,900		
Advance Angle (deg.)	Start	Below 0.5	1.7 ~ 2.7	Finish 5.5 ~ 6.5		

3. GOVERNOR ADJUSTMENT

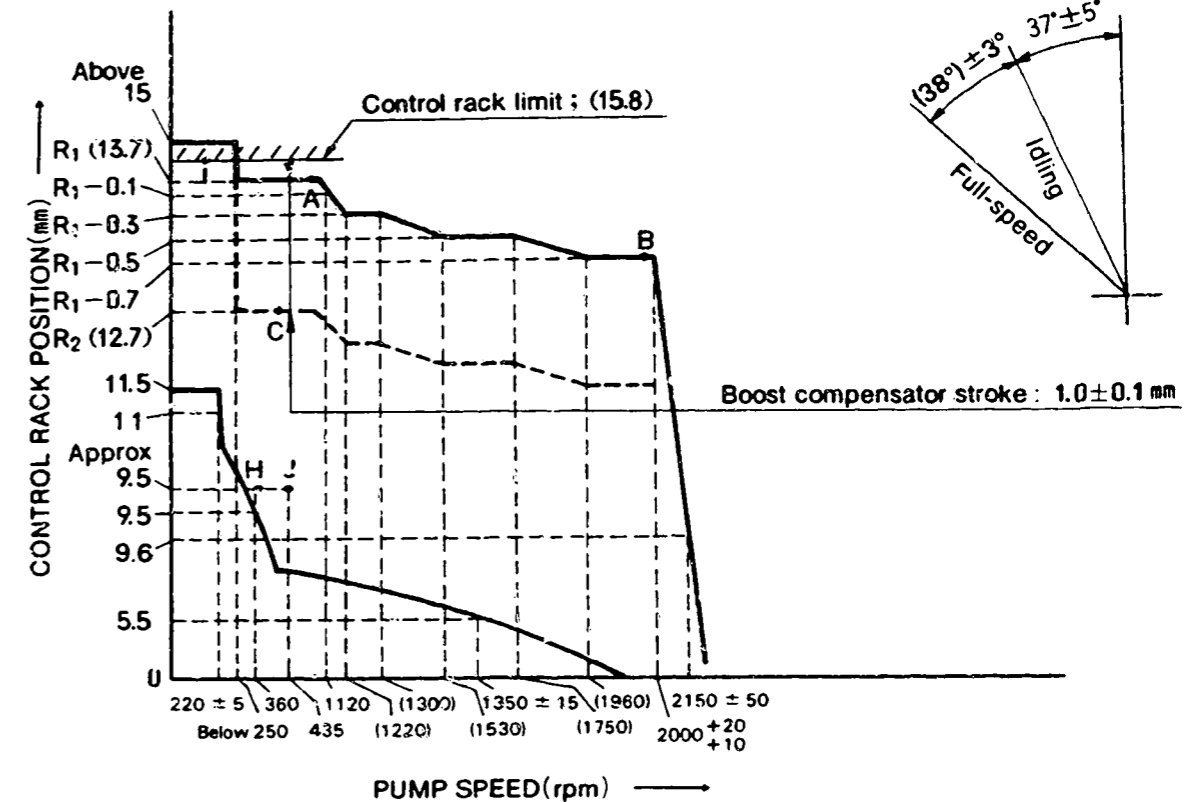

Idling Adjustment

Item	Pump Speed (rpm)	Rack Position (mm)	Remarks
Idling Lever Position: Temporary Setting	80~100	11.5	• Adjust using screw ①.
Idling Position Setting	360 215~225	9.5 11	• Adjust using spring capsule ①.
Governor Spring Contact Adjustment	1335 ~ 1365	5.5	• Adjust the governor shaft position. • Confirm
Setting the Idling Lever Position	360	Approx. 9.5	• Adjust using screw ①. • Confirm the control lever angle (32°~42°)

■ Full Load Adjustment (Torque Cam No. 74)

Item	Pump Speed (rpm)	Rack Position (mm)	Remarks
Full Speed Lever Position: Temporary Setting	Approx.2000	(13.7) - 0.7	• Adjust using screw ③. (Do not enter governor control range)
Full Load Position Adjustment	1000	13.7	• Adjust using screw ④.
Torque Cam Position Adjustment	1120	(13.7) - 0.1	• Adjust using screw ⑤.
	(1220)	(13.7) - 0.3	• Confirm
	(1300)	(13.7) - 0.3	• "
	(1530)	(13.7) - 0.5	• "
	(1750)	(13.7) - 0.5	• "
	(1960)	(13.7) - 0.7	• "
	—	—	• "
Confirm injection quantity at points A to B.			
Maximum Speed control Adjustment	2010 ~ 2020	(1.37) - 0.7	• Adjust using screw ③.
	2100 ~ 2200	9.6	• Confirm
	—	—	• After adjustment, confirm that the control lever angle is 40°~46°
Confirming Excess Fuel Limit for Engine Starting	435	Approx.9.5	• Set the control lever at point J.
	0	11.5	• Confirm
	0	Above 15	• Move the control lever to the "full-speed" position and then confirm the control rack position.
Confirm the Black Smoke Limit	Fix the control lever at point H. Then, operate the pump at 250 rpm. Confirm that the control rack does not move beyond 13.7 mm. When the control lever is moved to the "full-speed" position again increase the pump speed and confirm that the control rack starts to move from a pump speed of — rpm.		
Rack Limiter Adjustment	0	(15.8)	• Fix the control rack using screw Part No. 157954-3700
	Measure the depth of the control rack cap. Then, adjust screw ⑥ so that it equals the depth of the rack cap and install the rack cap. Confirm injection quantity at point I.		

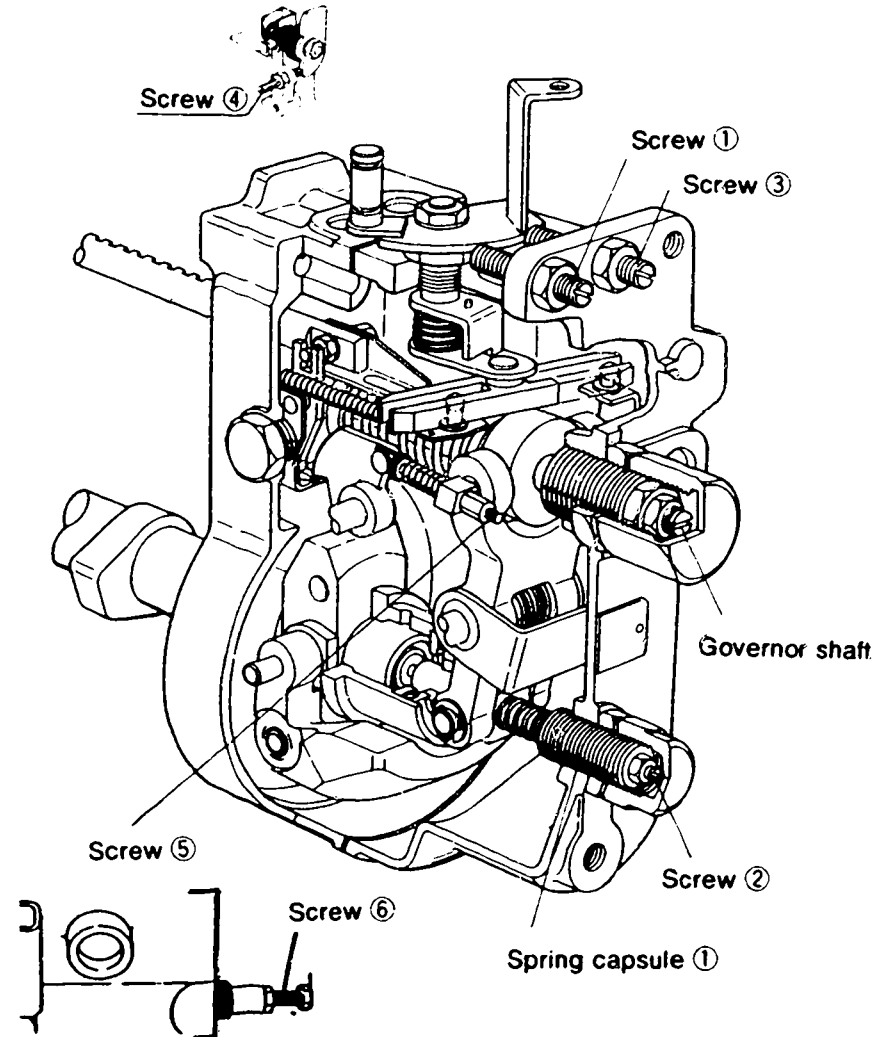

■ Boost Compensator Adjustment

- Maintain the pump speed at 700 rpm and fix the control lever in the full load position.
- In this condition, use calipers to measure the dimension "L" of the pushrod from the end face of the spacer. (Inspection: 23.9 to 24.1 mm)

Item	Pump Speed (rpm)	Rack Position (mm)	Remarks
Setting the Boost Compensator Spring Force	95~135	12.7	• Adjust using screw ⑦.
Boost Compensator Spring Adjustment (Boost compensator stroke: 1.0±0.1 mm)	0	13.7→12.7	• Adjust using screw ⑦.
	95~135	12.7	• Confirm
	300~350	13.7	• Confirm

101641-9152 5/5

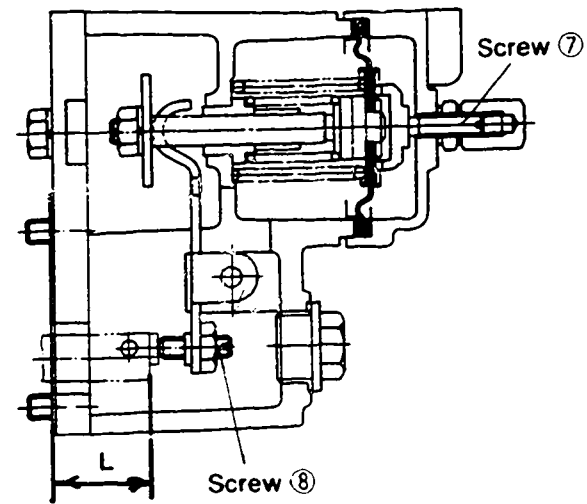
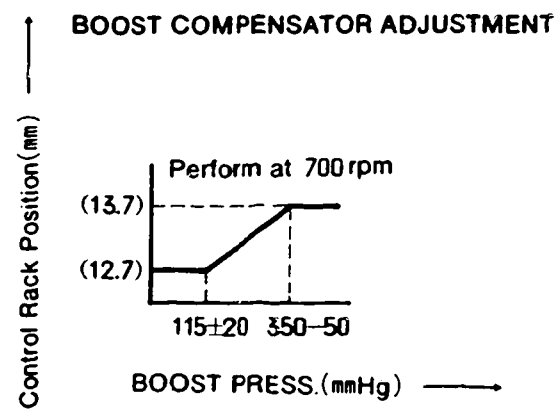

■ Timing Setting

At No. 1 plunger's beginning of injection position.
B.D.T.C. : 20

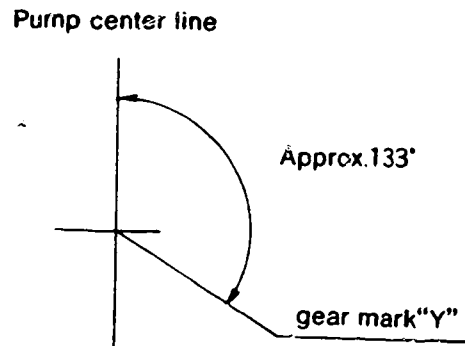

INJ. PUMP CALIBRATION DATA

Distributor-type

ENGINE MODEL : C223-T

BOSCH No. 9 460 610 259 1/2

DKKC No. 104740-1141

Date : 15. Oct. 1987 0

Company : ISUZU

No. 8 94144 850 1

TEST OIL:
I S O 4113 or
S A E J967d

Injection pump No: 104640-1022 [NP-VE4/10F2150RNP259]

Pump rotation : clockwise-viewed from drive side

Pre-stroke : mm

For Test Condition see
Microfiche No.WP-210(N16)

1. Setting	Pump speed (rpm)	Settings	Charge-air Press(mmHg)	Difference in delivery(cc)
1-1 Timing device travel	1,250	3.5~3.9 (mm)	0	
1-2 Supply pump pressure	1,250	4.6~5.0 (kg/cm ²)	0	
1-3 Full load delivery	1,250	47.8~48.8 (cc/1,000st)	590~610	4.0
1-4 Idle speed regulation	375	9.3~13.3 (cc/1,000st)	0	2.0
1-5 Start	100	Above 60.0 (cc/1,000st)	0	
1-6 Full-load speed regulation	2,550	19.9~25.9 (cc/1,000st)	590~610	7.0
1-7 CSD Adjustment	500~700	Cancel speed		
1-8				

○ CSD Adjustment

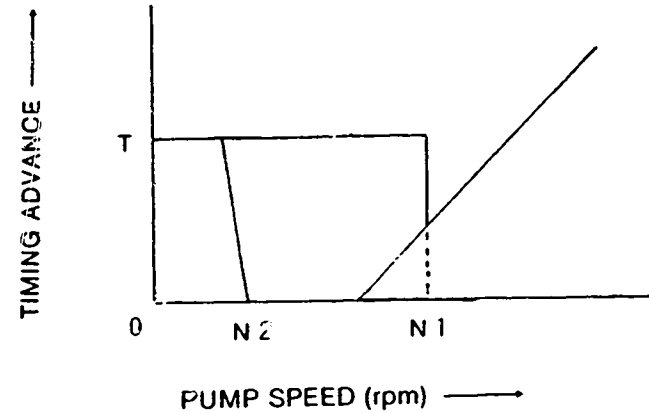

N1 (Cancel).....500~700rpm

N2.....Below 280rpm

T.....2.3~2.7mm

Upon canceling of CSD check the rotation and make sure no fuel leakage from the overflow of CSD

2. Test Specifications

2-1 Timing device	N = rpm	1,250	1,700	2,150
	mm	3.4~4.0	5.8~6.8	8.7~9.4
2-2 Supply pump	N = rpm	250	1,250	2,000
	kg/cm ²	1.6~2.2	4.6~5.0	6.1~6.7
2-3 Overflow delivery	N = rpm	1,000		
	cc/10s	40.8~84.2		

Speed control lever	Pump speed (rpm)	Fuel delivery (cc/1,000st)	Charge-air Press(mmHg)	Difference in delivery
End stop	1,250	47.3~49.3	590~610	
	600	34.1~39.1	0	
	900	42.7~44.7	290~310	
	1,150	46.5~51.5	590~610	
	1,250	34.1~39.1	0	
	2,000	38.4~43.4	590~610	
	2,175	36.7~41.7	590~610	
	2,550	19.4~26.4	590~610	
Switch OFF	375	0	0	
	450	Below 3.0	0	
Idle stop	375	9.3~13.3	0	
	450	Below 3.0	0	

3. Dimensions

K	3.2~3.4	mm
KF	5.7~5.9	mm
N/S	1.5~1.7	mm
BCS	3.4~3.6	mm

Control lever angle

α	21.0~27.0	deg
A	9.2~11.0	mm
β	37.0~47.0	deg
B	12.0~15.0	mm
γ	—	deg
C	—	mm

2-5 Solenoid Voltage : 12 V

INJ. PUMP CALIBRATION DATA

Distributor-type

MOTOR : LD20T

TEST OIL:
ISO 4113 or
SAE J967d

Injection pump No: 104640-2061 [NP-VE4/10F2400RNP408]

Pump rotation : clockwise-viewed from drive side

Pre-stroke : — mm

BOSCH No. 9 460 610 260 1/3

DKKC No. 104740-2061

Date : 15. Oct. 1987 ①

Company : NISSAN

No. 1670013C00

For Test Condition see
Microfiche No.WP-210(N16)

104740-2061 2/3

1. Setting	Pump speed (rpm)	Settings	Charge air press(mmHg)	Difference in delivery(cc)
1-1 Timing device travel	900	T=1.0~1.4 (mm)	255~275	
1-2 Supply pump pressure	900	3.2~3.8 (kg/cm ²)	255~275	
1-3 Full load delivery without charge air pressure	600	29.7~30.7 (cc/1,000st)	0	2.5
Full load delivery with charge air pressure	900	39.5~40.5 (cc/1,000st)	255~275	
1-4 Idle speed regulation	360	4.6~7.6 (cc/1,000st)	0	2.5
1-5 Start	100	40.0~50.0 (cc/1,000st)	0	
1-6 Full-load speed regulation	2,700	6.7~12.7 (cc/1,000st)	474~494	
1-7 Load-timer Adjustment	900	T=0.65±0.2mm		
1-8				

2. Test Specifications

2-1 Timing device	N = rpm	900	1,200	2,400
	mm	0.9~1.5	2.8~3.6	8.1~9.0
2-2 Supply pump	N = rpm	900	1,200	2,400
	kg/cm ²	3.1~3.9	3.8~4.6	6.9~7.7
2-3 Overflow delivery	N = rpm	900		
	cc/10s	41.0~86.0		
2-4 Fuel injection quantities				
Speed control lever position	Pump speed (rpm)	Fuel delivery (cc/1,000st)	Charge air press(mmHg)	Difference in delivery(cc)
Full speed position	600	29.2~31.2	0	
	900	39.0~41.0	255~275	
	2,200	34.8~38.8	490~510	
	2,700	5.2~12.2	474~494	
	2800	Below 6.0	474~494	
Switch OFF	360	0	0	
Idling position	360	4.1~8.1	0	
	500	Below 3.0	0	
Partial load	900	2.0~12.0	255~275	
2-5 Solenoid	Max.cut-in voltage : 8 V Test voltage : 12~14 V			

3. Dimensions

K	3.20~3.40 mm
KF	5.65~5.85 mm
MS	0.80~1.00 mm
BCS	— mm

Control lever angle

α	21.0~29.0 deg
A	4.3~9.6 mm
β	36.0~46.0 deg
B	10.9~14.6 mm
γ	10.5~11.5 deg
C	6.9~7.5 mm

○ Note

■ After adjustment of full load fuel injection quantity (600 rpm, 29.7~30.7 cc/1000st) set the boost pressure at 255~275 mmHg, and at a pump speed of 900 rpm adjust the fuel injection quantity using the BCS spring set screw.

LOAD TIMER ADJUSTMENT

1) Adjustment

① Fix the control lever in the position satisfying the following conditions.

Boost Pressure : — mmHg

Pump Speed : 900 rpm

Fuel Injection : 17±1 cc/1000st
Quantity

② With the control lever positioned as described in ① above, adjust the governor sleeve so that the Timer Stroke conforms to the specified values (page 1 / 3)

Starting Injection Quantity Adjustment

Adjust the starting injection quantity (item 1 / 5) using the adjusting bolt (as shown in the figure at right).

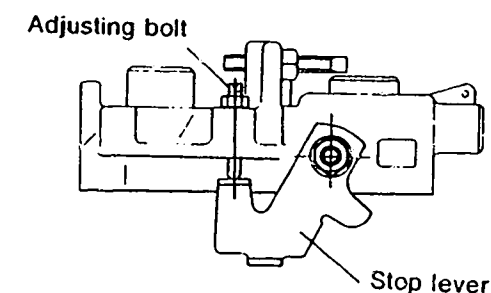

■ M-CSD Adjustment

1) Fix the intermediate lever adjustment screw in position (adjust with the M-CSD released)

1. Hold the control lever (3) in the idling position.
2. Move the adjusting screw to a horizontal position.
3. Adjust using the adjusting screw (1) so that the gap between the control lever (3) and the adjusting screw (1) is 1~2 mm, and then fix the screw using the nut.

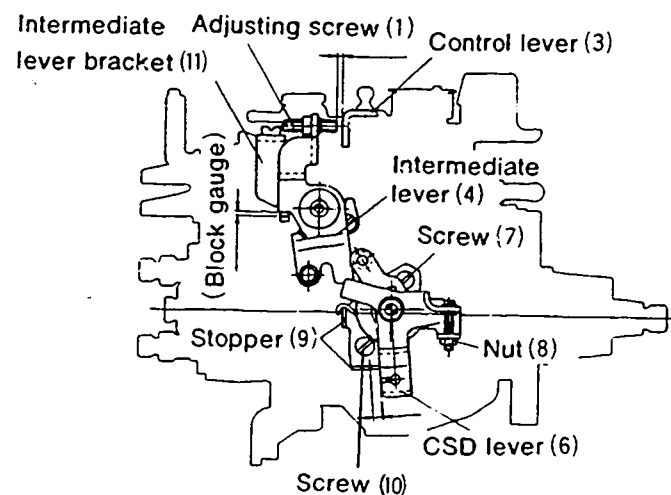

2) Fixing the M-CSD Stopper (9)

1. Turn the drive shaft slowly and fix the drive shaft in a position where a load is applied (the point where the roller in the roller holder contacts the cam surface of the cam disc) .
2. Move the CSD lever (6) to the advance side.
3. Fix the CSD lever in the position where the ball pin at the tip of the shaft lightly contacts the roller holder (roller holder advance angle "0") .
4. Move the CSD lever to the advance side.
5. Then, adjust the position of the stopper (9) so that the timer stroke is 1.2 ± 0.2 mm and fix the stopper (9) using the screw (10).

3) Screw (7) Adjustment

1. Fix the control lever in the idling position.
2. Move the CSD lever to the advance side.
3. Then, adjust the screw (7) so that the clearance between the control lever and the idling stopper bolt is 7.2 ± 0.5 mm, and fix the screw (7) using the nut (8) .

INJ. PUMP CALIBRATION DATA

TEST OIL:
ISO 4113 or
SAE J967d

Distributor-type

ENGINE MODEL : SD23

Injection pump No: 104640-4681 [NP-VE4/10F2150RNP340]

BOSCH No. 9 460 610 261

DKKC No. 104740-4712

Date: 15. Oct. 1987 2

Company: NISSAN DIESEL

No. 16700 18G0?

Pump rotation : clockwise-viewed from drive side

Pre-stroke : 0.18~0.22 mm

For Test Condition see
Microfiche No.WP-210(N16)

1. Setting	Pump speed (rpm)	Settings	Charge air press(mmHg)	Difference in delivery(cc)
1-1 Timing device travel	1,000	1.5~ 1.9 (mm)		
1-2 Supply pump pressure	1,000	4.0~ 4.6 (kg/cm ²)		
1-3 Full load delivery without charge air pressure	1,000	35.6~36.6 (cc/1,000st)		3.0
Full load delivery with charge air pressure		(cc/1,000st)		
1-4 Idle speed regulation	300	4.3~ 8.3 (cc/1,000st)		2.0
1-5 Start	100	45.0~80.0 (cc/1,000st)		
1-6 Full-load speed regulation	2,450	8.6~15.6 (cc/1,000st)		
1-7				
1-8				

2. Test Specifications

2-1 Timing device	N = rpm	1,000	1,400	2,150
	mm	1.4~ 2.0	2.6~ 3.8	5.6~ 6.8
2-2 Supply pump	N = rpm	1,000	1,400	2,150
	kg/cm ²	4.0~ 4.6	5.0~ 5.6	6.8~ 7.4
2-3 Overflow delivery	N = rpm	1,000		
	cc/10s	8.0~52.0		

2-4 Fuel deliveries

Speed control lever	Pump speed (rpm)	Fuel delivery (cc/1,000st)	Charge air press(mmHg)	Difference in delivery
End stop	2,600	Below 5.0		
	2,450	8.1~16.1		
	2,150	31.9~35.9		
	1,000	35.1~37.1		
	600	30.3~34.3		
Switch OFF	300	0		
Idle stop	300	4.3~ 8.3		
	350	Below 3.0		

3. Dimensions

K	3.2 ~3.4	mm
KF	5.65~5.85	mm
MS	1.1 ~1.3	mm
BCS	—	mm

Control lever angle

α	21.0~29.0	deg
A	4.0~ 9.2	mm
β	41.0~51.0	deg
B	18.6~22.6	mm
γ	—	deg
C	—	mm

2-5 Solenoid Max cut-in voltage : 8 V
Test voltage : 12~14 V

INJ. PUMP CALIBRATION DATA

Distributor-type

ENGINE MODEL : PN

TEST OIL:
I S O 4113 or
S A E J967d

Injection pump No: 104649-0331 [NP-VE4/9F2350RNP355]

Pump rotation : clockwise-viewed from drive side

Pre-stroke : — mm

BOSCH No. 9 460 610 262 1/4

DKKC No. 104749-0294

Date : 15. Oct. 1987

Company : MAZDA

No. PN13 13 800E

For Test Condition see
Microfiche No.WP-210(N16)

1. Setting	Pump speed (rpm)	Settings	Charge air press(mmHg)	Difference in delivery(cc)
1-1 Timing device travel	1,500	3.4~ 3.8 (mm)		
1-2 Supply pump pressure	1,500	4.4~ 5.0 (kg/cm ²)		
1-3 Full load delivery without charge air pressure	1,500	34.6~35.6 (cc/1,000st)		2.5
Full load delivery with charge air pressure		(cc/1,000st)		
1-4 Idle speed regulation	410	5.0~ 7.0 (cc/1,000st)		2.0
1-5 Start	100	55.0~70.0 (cc/1,000st)		
1-6 Full-load speed regulation	2,635	6.0~10.0 (cc/1,000st)		
1-7 Load-timer adjustment	1,500	2.9± 0.2 (mm)		
1-8				

2. Test Specifications

2-1 Timing device	N = rpm	1,000	1,500	2,350
	mm	0.6~ 1.8	3.3~ 3.9	7.1~ 8.3
2-2 Supply pump	N = rpm	1,000	1,500	2,350
	kg/cm ²	3.0~ 3.6	4.4~ 5.0	6.8~ 7.4
2-3 Overflow delivery	N = rpm	1,500		
	cc/10s	52.0~97.0		
2-4 Fuel injection quantities				
Speed control lever position	Pump speed (rpm)	Fuel delivery (cc/1,000st)	Charge air press(mmHg)	Difference in delivery(cc)
Full speed position	1,500	34.1~36.1		
	500	30.4~38.4		
	2,350	29.2~33.2		
	2,635	5.0~11.0		
	2,800	Below 3.0		
Switch OFF	410	0		
Idling position	410	5.0~ 9.0		
2-5 Solenoid				
		Max.cut-in voltage : 3 V		
		Test voltage : 12~14 V		

3. Dimensions

K	3.2~3.4	mm
KF	5.7~5.9	mm
MS	1.4~1.6	mm
BCS	—	mm
Control lever angle		
α	23.0~27.0	deg
A	34.5~37.5	mm
β	38.0~48.0	deg
B	11.9~15.2	mm
γ	—	deg
C	—	mm

LOAD TIMER ADJUSTMENT

1) Adjustment

① Fix the control lever in the position satisfying the following conditions.

Boost Pressure : — mmHg

Pump Speed : 1500 rpm

Fuel Injection : 31.2±1 cc/1000st
Quantity

② With the control lever positioned as described in ① above, adjust the governor sleeve so that the Timer Stroke conforms to the specified values (page 1/4)

2) Confirmation of Timer Characteristics

Fix the control lever in the position satisfying the following conditions, and confirm the Timer Stroke.

Control lever position			Specified Values	
Pump speed (rpm)	Fuel Injection Quantity(cc/1000st)	Boost pressure (mmHg)	Timer stroke (mm)	Timer stroke reduction value (mm)
1500	31±1.5	—	2.9±0.3	—
1500	22±1.5	—	(1.9)	—

■ Side link lever adjustment

1) Side link lever adjustment

1. Fix the control lever in the idling position.
2. Confirm that the side link lever ② contact the stopper ③ through the springs action.
3. Rotate the side link lever ① gently in P direction so that the connecting rod ④ play is zero mm.
4. Adjust the length of rod ④ so that the gap at the levers ① and ② is 0.8 ± 0.2 mm.
5. Tighten the two nuts on rod ④.

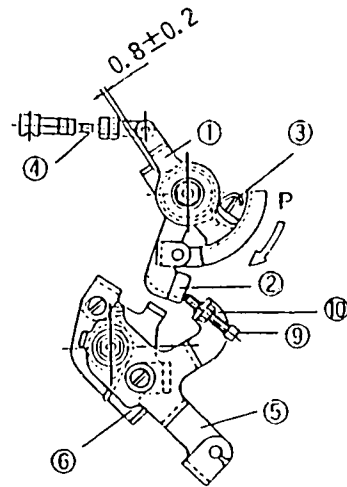

2) Fixing the M-CSD stopper

1. Fix the M-CSD assembly temporarily to the pump housing.
2. Turn the drive shaft at least two turns in the direction of pump rotation.
3. Turn the drive shaft slowly, and fix the drive shaft in a position where a load is applied (the point where the roller in the roller holder contacts the cam surface of the cam disk).
4. Move the CSD lever to the advance side.
5. Fix the CSD lever ⑤ in the position where the ball pin at the tip of the shaft lightly contacts the roller holder (roller holder advance angle "0").
6. Adjust using the adjusting screw ⑦ so that the gap between the CSD lever ⑤ and the stopper ⑥ is 0.5 ± 2 mm.
7. After adjust, tighten the nut ⑧ to the specified torque.
 $T = 0.6$ to 0.9 kg.m

3) M-CSD Adjustment

1. Move the CSD lever ⑤ through its full stroke.
2. Adjust the screw ⑨ so that the gap between the control lever ⑪ and idling adjusting bolt is 4.1 ± 0.5 mm, and then fix in the this position.

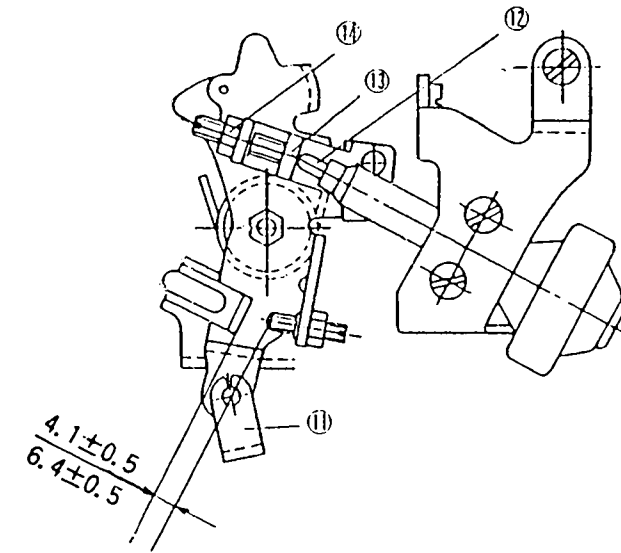

■ DASH POT ADJUSTMENT

- ① Insert a block gauge (thickness gauge) of thickness 6.4 ± 0.5 in the gap between the idling stopper bolt and the bracket. (control lever angle : 15.2°)
- ② With the control lever positioned as described in ① above, adjust the Dashpot adjusting screw ⑭ so that the Dashpot adjusting screw ⑭ and the push rod ⑰ are in contact. Fix using the nut.

INJ. PUMP CALIBRATION DATA

Distributor-type

ENGINE MODEL : PN

BOSCH No. 9 460 610 263 1/4

DKKC No. 104749-0323

Date : 15. Oct. 1987

Company : MAZDA

No. PN2213800C

For Test Condition see
Microfiche No.WP-210(N16)

104749-0323 2/4

TEST OIL:
ISO 4113 or
SAE J967d

Injection pump No: 104649-0343 [NP-VE4/9F2350RNP540]

Pump rotation : clockwise-viewed from drive side

Pre-stroke : — mm

1. Setting	Pump speed (rpm)	Settings	Charge air press(mmHg)	Difference in delivery(cc)
1-1 Timing device travel	1,500	3.7~ 4.1 (mm)		
1-2 Supply pump pressure	1,500	4.4~ 5.0 (kg/cm ²)		
1-3 Full load delivery without charge air pressure	1,500	35.6~36.6 (cc/1,000st)		2.5
Full load delivery with charge air pressure		(cc/1,000st)		
1-4 Idle speed regulation	410	5.0~ 7.0 (cc/1,000st)		2.0
1-5 Start	100	55.0~75.0 (cc/1,000st)		
1-6 Full-load speed regulation	2,635	6.0~10.0 (cc/1,000st)		
1-7 Load-timer Adjustment	1,500	3.2±0.2 (mm)		
1-8				

2. Test Specifications

2-1 Timing device	N = rpm	1,000	1,500	2,350
	mm	1.0~ 2.2	3.6~ 4.2	7.1~ 8.3
2-2 Supply pump	N = rpm	1,000	1,500	2,350
	kg/cm ²	3.0~ 3.6	4.4~ 5.0	6.8~ 7.4
2-3 Overflow delivery	N = rpm		1,500	
	cc/10s		53.0~97.0	
2-4 Fuel injection quantities				
Speed control lever position	Pump speed (rpm)	Fuel delivery (cc/1,000st)	Charge air press(mmHg)	Difference in delivery(cc)
Full speed position	1,500	35.1~37.1		
	500	31.2~39.2		
	2,350	29.3~33.3		
	2,635	5.0~11.0		
	2,800	Below 3.0		
Switch OFF	410	0		
Idling position	410	5.0~ 7.0		
2-5 Solenoid				
		Max.cut-in voltage : 8 V		
		Test voltage : 12~14 V		

3. Dimensions

K	3.2~3.4	mm
KF	5.7~5.9	mm
MS	1.4~1.6	mm
BCS	—	mm

Control lever angle

α	23.0°~27.0°	deg
A	34.5~ 7.5	mm
β	38.0°~48.0°	deg
B	11.9~15.2	mm
γ	—	deg
C	—	mm

LOAD TIMER ADJUSTMENT

1) Adjustment

① Fix the control lever in the position satisfying the following conditions.

Boost Pressure :	—	mmHg
Pump Speed :	1500	rpm
Fuel Injection Quantity :	32.2±1	cc/1000st

② With the control lever positioned as described in ① above, adjust the governor sleeve so that the Timer Stroke conforms to the specified values (page 1 / 4)

2) Confirmation of Timer Characteristics

Fix the control lever in the position satisfying the following conditions, and confirm the Timer Stroke.

Control lever position			Specified Values	
Pump speed (rpm)	Fuel Injection Quantity(cc/1000st)	Boost pressure (mmHg)	Timer stroke (mm)	Timer stroke reduction value (mm)
1500	32.2±1.5	—	3.2±0.3	—
1500	23.1±1.5	—	(2.2)	—

■ Side Link Lever Adjustment

1) Side Link Lever Adjustment

1. Fix the control lever in the idling position.
2. Move the side link lever ② so that it contacts the stopper ③.
3. Rotate the side link lever ① gently in the direction of P so that the connecting rod ④ play is 0 mm.
4. Adjust the length of rod ④ so that the gap between the levers ① and ② is 0.8 ± 0.2 mm.
5. Tighten the two nuts on rod ④.

2) Fixing the M-CSD Stopper

1. Fix the M-CSD assembly to the pump housing.
2. Turn the drive shaft at least two turns in the direction of pump rotation.
3. Turn the drive shaft slowly, and fix the drive shaft in a position where a load is applied (the point where the roller in the roller holder contacts the cam surface of the cam disk).
4. Move the CSD lever to the advance side.
5. Fix the CSD lever in the position where the ball pin at the tip of the shaft lightly contacts the roller holder (roller holder advance angle "0").
6. Adjust using the adjusting screw ⑦ so that the gap between the CSD lever ⑤ and the stopper ⑥ is 0.5 ± 2 mm.
7. After adjustment, tighten the nut ⑧ to the specified torque.

Tightening torque : 0.6 to 0.9 kg.m

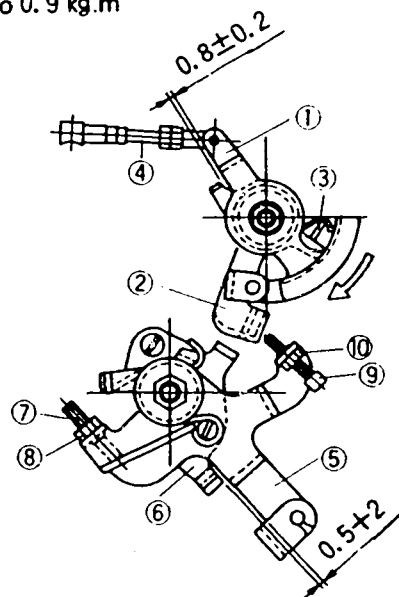

3) M-CSD Adjustment

1. Move the M-CSD lever ⑤ through its full stroke.
2. Adjust the screw ⑨ so that the gap between the control lever ⑪ and the idling adjusting bolt is 4.1 ± 0.5 mm, and then fix the screw ⑨ in this position.

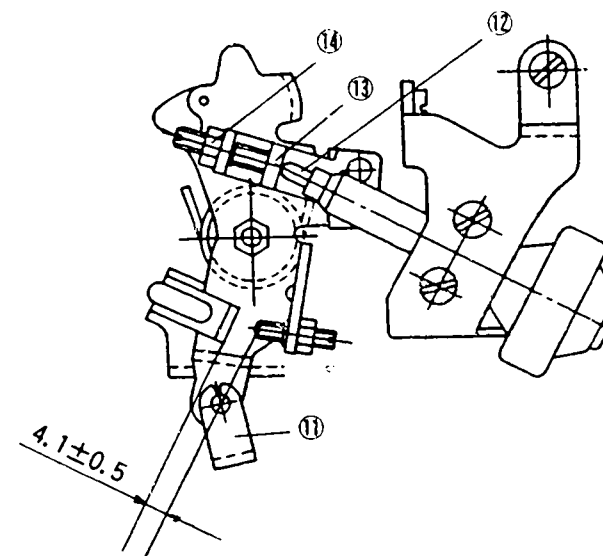

■ DASHPOT ADJUSTMENT.

1. Fix the control lever (11) in the idling position.
2. Adjust the screw (13) so that the pushrod (12) protrudes 2.3 ± 0.3 mm.

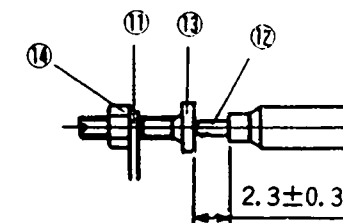

INJ. PUMP CALIBRATION DATA

Distributor-type

TEST OIL:
I S O 4113 or
S A E J967d

ENGINE MODEL : PN

Injection pump No: 104649-0381 (NP-VE4/9F2350RNP540)

Pump rotation : clockwise-viewed from drive side

Pre-stroke : — mm

BOSCH No. 9 460 810 264 1/4

DKKC No. 104749-0333

Date : 15. Oct. 1987 ①

Company : MAZDA

No. PN23 13 800C

For Test Condition see
Microfiche No.WP-210(N16)

104749-0333 2/4

1. Setting	Pump speed (rpm)	Settings	Charge air press(mmHg)	Difference in delivery(cc)
1-1 Timing device travel	1,500	3.7~ 4.1 (mm)		
1-2 Supply pump pressure	1,500	4.4~ 5.0 (kg/cm ²)		
1-3 Full load delivery without charge air pressure	1,500	35.6~36.6 (cc/1,000st)		2.5
Full load delivery with charge air pressure		(cc/1,000st)		
1-4 idle speed regulation	410	5.0~ 7.0 (cc/1,000st)		2.0
1-5 Start	100	55.0~70.0 (cc/1,000st)		
1-6 Full-load speed regulation	2,635	6.0~10.0 (cc/1,000st)		
1-7 Load-timer adjustment	1,500	3.2± 0.2 (mm)		
1-8				

2. Test Specifications

2-1 Timing device	N = rpm	1,000	1,500	2,350
	mm	1.0~ 2.2	3.6~ 4.2	7.1~ 8.3
2-2 Supply pump	N = rpm	1,000	1,500	2,350
	kg/cm ²	3.0~ 3.6	4.4~ 5.0	6.8~ 7.4
2-3 Overflow delivery	N = rpm	1,500		
	cc/10s	53.0~97.0		

2-4 Fuel injection quantities

Speed control lever position	Pump speed (rpm)	Fuel delivery (cc/1,000st)	Charge air press(mmHg)	Difference in delivery(cc)
Full speed position	1,500	35.1~37.1		
	500	31.2~39.2		
	2,350	29.3~33.3		
	2,635	5.0~11.0		
	2,800	Below 3.0		

Switch OFF	410	0		
Idling position	410	5.0~ 7.0		

2-5 Solenoid	Max.cut-in voltage : 8 V
	Test voltage : 12~14 V

3. Dimensions

K	3.2~3.4	mm
KF	5.7~5.9	mm
MS	1.4~1.6	mm
BCS	—	mm

Control lever angle

α	23.0°~27.0°	deg
A	34.5~37.5	mm
β	38.0°~48.0°	deg
B	11.9~15.2	mm
Y	—	deg
C	—	mm

■ Side Link Lever Adjustment

1) Side Link Lever Adjustment

1. Fix the control lever in the idling position.
2. Move the side link lever ② so that it contacts the stopper ③.
3. Rotate the side link lever ① gently in the direction of P so that the connecting rod ④ play is 0 mm.
4. Adjust the length of rod ④ so that the gap between the levers ① and ② is 0.8±0.2 mm.
5. Tighten the two nuts on rod ④.

2) Fixing the M-CSD Stopper

1. Fix the M-CSD assembly temporarily to the pump housing.
2. Turn the drive shaft at least two turns in the direction of pump rotation.
3. Turn the drive shaft slowly, and fix the drive shaft in a position where a load is applied (the point where the roller in the roller holder contacts the cam surface of the cam disk).
4. Move the CSD lever to the advance side.
5. Fix the CSD lever in the position where the ball pin at the tip of the shaft lightly contacts the roller holder (roller holder advance angle "0").
6. Adjust using the adjusting screw ⑦ so that the gap between the CSD lever ⑤ and the stopper ⑥ is 0.5+2 mm.
7. After adjustment, tighten the nut ⑧ to the specified torque.

Tightening torque : 0.6 to 0.9 kg.m

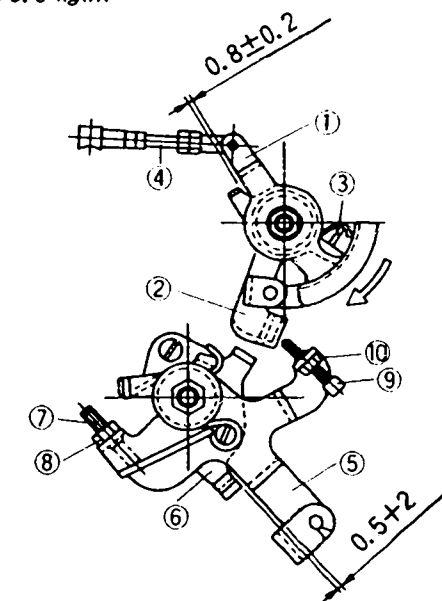

3) M-CSD Adjustment

1. Move the M-CSD lever ⑤ through its full stroke.
2. Adjust the screw ⑨ so that the gap between the control lever ⑪ and the idling adjusting bolt is 4.1 ± 0.5 mm, and then fix the screw ⑨ in this position.

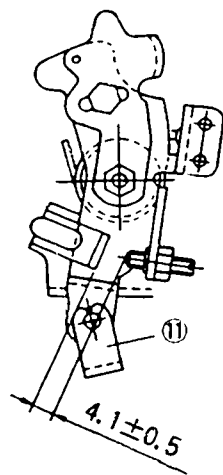

LOAD TIMER ADJUSTMENT

1) Adjustment

- ① Fix the control lever in the position, satisfying the following conditions.

Boost Pressure : — mmHg
 Pump Speed : 1500 rpm
 Fuel Injection Quantity : 32.2 ± 1 cc/1000st

- ② With the control lever positioned as described in ① above, adjust the governor sleeve so that the Timer Stroke conforms to the specified values (page 1 / 4)

2) Confirmation of Timer Characteristics

Fix the control lever in the position satisfying the following conditions, and confirm the Timer Stroke.

Control lever position			Specified Values	
Pump speed (rpm)	Fuel Injection Quantity(cc/1000st)	Boost pressure (mmHg)	Timer stroke (mm)	Timer stroke reduction value (mm)
1500	32.2 ± 1.5	—	3.2 ± 0.3	—
1500	23.1 ± 1.5	—	(2.2)	—

INJ. PUMP CALIBRATION DATA

Distributor-type

ENGINE MODEL : LD20E

TEST OIL:
I S O 4113 or
S A E J967d

Injection pump No: 104649-2231 [NP-VE4/9F2200RNP465]

Pump rotation : clockwise-viewed from drive side

Pre-stroke : - mm

BOSCH No. 9 460 610 265

DKKC No. 104749-2231

Date : 15. Oct. 1987

Company : NISSAN(MISA)

No. 16700 D9702

For Test Condition see
Microfiche No.WP-210(N16)

1. Setting	Pump speed (rpm)	Settings	Charge air press(mmHg)	Difference in delivery(cc)
1-1 Timing device travel	900	T=1.3~ 1.7 (mm)		
1-2 Supply pump pressure	900	3.2~ 3.8 (kg/cm ²)		
1-3 Full load delivery without charge air pressure	2,200	30.2~ 31.2 (cc/1,000st)		2.5
Full load delivery with charge air pressure		(cc/1,000st)		
1-4 Idle speed regulation	350	4.7~ 7.7 (cc/1,000st)		
1-5 Start	100	40.0~50.0 (cc/1,000st)		
1-6 Full-load speed regulation	2,570	10.4~16.4 (cc/1,000st)		
1-7 Load-timer adjustment	900	0.65± 0.20 (mm)		
1-8				

2. Test Specifications

2-1 Timing device	N = rpm	900	1,800	2,200
	mm	1.2~1.8	5.5~ 6.7	7.2~ 8.4
2-2 Supply pump	N = rpm	900	1,800	2,200
	kg/cm ²	3.1~ 3.9	5.1~ 5.9	6.0~ 6.8
2-3 Overflow delivery	N = rpm cc/10s	900 35.0~79.0		

2-4 Fuel injection quantities

Speed control lever position	Pump speed (rpm)	Fuel delivery (cc/1,000st)	Charge air press(mmHg)	Difference in delivery(cc)
Full speed position	2,200	29.7~31.7		
	900	29.0~33.0		
	2,570	9.9~16.9		
	2,800	Below 6.0		
Switch OFF Idling position	350	0		
	500	4.2~ 8.2 Below 3.0		2.5
Partial load	900	4.1~14.1		

2-5 Solenoid Max cut-in voltage : 8 V
Test voltage : 12~14 V

3. Dimensions

K	3.2~3.4	mm
KF	5.7~5.9	mm
MS	1.1~1.3	mm
BCE	—	mm

Control lever angle

α	21.0~29.0	deg
A	4.3~ 9.6	mm
β	36.0~46.0	deg
B	10.9~14.6	mm
γ	10.5~11.5	deg
C	6.9~ 7.5	mm

■ Starting Injection Quantity Adjustment

Adjust the starting injection quantity
(item 1/5) using the adjusting bolt
(as shown in the figure at right) .

Adjusting bolt

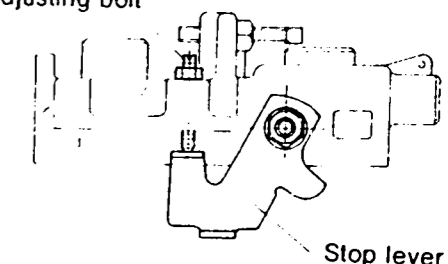

■ M-CSD Adjustment

- 1) Fix the intermediate lever adjustment screw in position. (Adjust with the M-CSD released)
 1. Hold the control lever (3) in the idling position.
 2. Move the adjusting screw to a horizontal position.
 3. Adjust using the adjusting screw (1) so that the gap between the control lever (3) and the adjusting screw (1) is 1~2mm, and then fix using the nut.

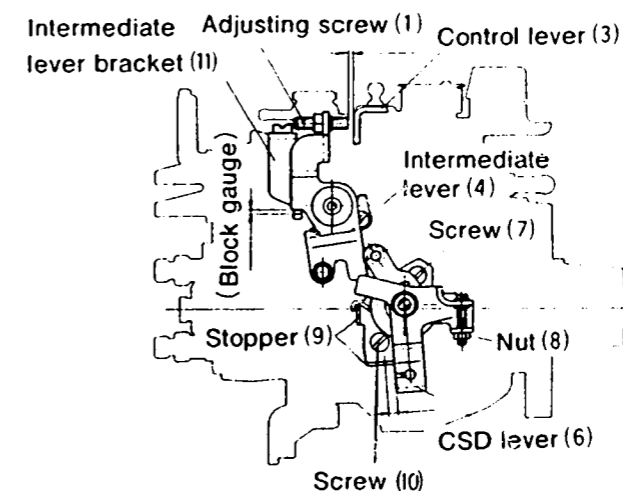

2) Fixing the M-CSD stopper (9):

1. Turn the drive shaft slowly, and fix the drive shaft in a position where a load is applied (the point where the roller in the roller holder contacts the cam surface of the cam disc).
2. Move the CSD lever (6) to the advance side.
3. Fix the CSD lever in the position where the ball pin at the tip of the shaft lightly contacts the roller holder (roller holder advance angle "0").
4. Move the CSD lever to the advance side.
5. Then, adjust the position of the stopper (9) so that the timer stroke is 1.8 ± 0.2 mm, and fix the stopper (9) using the screw (10).

3) Screw (7) Adjustment

1. Fix the control lever in the idling position.
2. Move the CSD lever to the advance side.
3. Then, adjust the screw (7) so that the clearance between the control lever and the idling stopper bolt is 7.2 ± 0.5 mm, and fix the screw (7) using the nut (8).

INJ.PUMP CALIBRATION DATA

Distributor-type

ENGINE MODEL : RD28

TEST OIL:
ISO 4113 or
SAE J967d

Injection pump No: 104669-2112 [NP-VE6/9F2500RNP40]

Pump rotation : clockwise-viewed from drive side

Pre-stroke : mm

BOSCH No. 9 460 610 266 1/4

DKKC No. 104769-2104

Date : 15. Oct. 1987

Company : NISSAN

No. 16700 V7213

For Test Condition see
Microfiche No.WP-210(N16)

1. Setting	Pump speed (rpm)	Settings	Charge air press(mmHg)	Difference in delivery(cc)
1-1 Timing device travel	900	1.2 ~ 1.6 (mm)		
1-2 Supply pump pressure	900	3.5 ~ 4.1 (kg/cm ²)		
1-3 Full load delivery without charge air pressure	900	30.9 ~ 31.9 (cc/1,000st)		2.5
Full load delivery with charge air pressure		(cc/1,000st)		
1-4 Idle speed regulation	350	5.8 ~ 8.8 (cc/1,000st)		
1-5 Start	100	40.8 ~ 48.8 (cc/1,000st)		
1-6 Full-load speed regulation	2,600	15.5 ~ 21.5 (cc/1,000st)		
1-7				
1-8				

2. Test Specifications

2-1 Timing device	N = rpm	900	1,200	2,300
	mm	1.1 ~ 1.7	2.7 ~ 3.5	8.1 ~ 9.0
2-2 Supply pump	N = rpm	900	1,800	2,500
	kg/cm ²	3.4 ~ 4.2	5.5 ~ 6.3	7.2 ~ 8.0
2-3 Overflow delivery	N = rpm	900		
	cc/10s	43.0 ~ 87.0		

2-4 Fuel deliveries

Speed control lever	Pump speed (rpm)	Fuel delivery (cc/1,000st)	Charge air press(mmHg)	Difference in delivery
End stop	2,800	Below 5.0		
	2,600	15.0 ~ 22.0		
	2,300	28.0 ~ 32.0		
	900	30.4 ~ 32.4		
	600	29.1 ~ 33.1		
Switch OFF	350	0		
Idle stop	350	5.3 ~ 9.3		1.9
	500	Below 4.0		
Partial load	900	2.5 ~ 12.5		

2-5 Max.cut-in voltage : 8 V
Solenoid Test voltage : 12~14 V

3. Dimensions

K	3.2 ~ 3.4	mm
KF	6.54 ~ 6.74	mm
MS	1.7 ~ 1.9	mm
BCS	—	mm

Control lever angle

α	19.0 ~ 27.0	deg
A	8.7 ~ 12.9	mm
β	37.0 ~ 47.0	deg
B	11.5 ~ 15.2	mm
γ	10.5 ~ 11.5	deg
C	5.7 ~ 6.3	mm

W-CSD Adjustment

1) Timer Stroke Adjustment

1. Calculate the timer stroke from Fig. 2 according to the atmospheric temperature at the time of adjustment.
2. Adjust using the timer stroke adjusting screw so that the timer stroke is as calculated in Step 1.

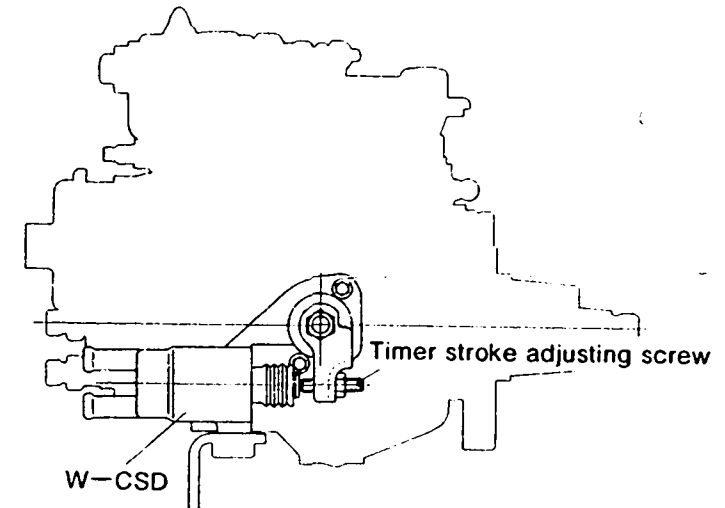

Fig. 1

Formula for calculating Fig. 2

Formula for calculating timer stroke:

$$\text{When } -10 \leq t(^{\circ}\text{C}) \leq 20 \quad T = -0.0367t + 1.284$$

$$\text{When } 20 \leq t(^{\circ}\text{C}) \leq 40 \quad T = -0.0275t + 1.1$$

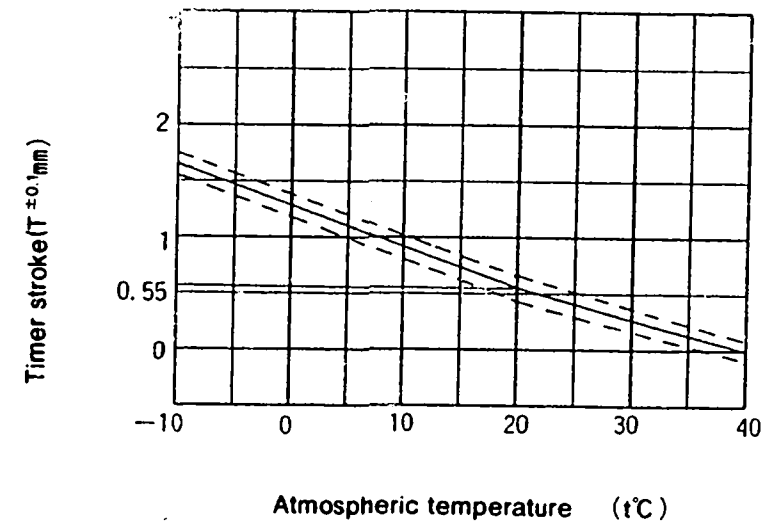
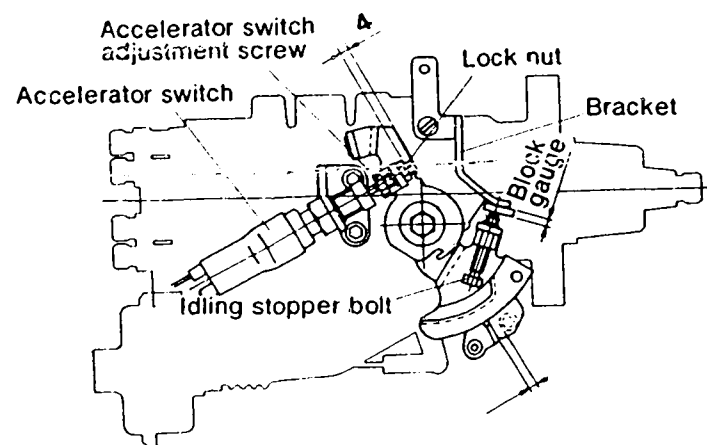

Fig. 2

■ Accelerator Switch Adjustment

1. Adjust so that the accelerator switch adjustment screw protrudes 4 mm from the locknut, and then lock in position.
2. Insert a block gauge of 2.5 ± 0.1 mm thickness between the idling stopper bolt and the bracket.
3. Then, adjust the installation position of the accelerator switch so that it is turned



■ DASH POT ADJUSTMENT

- ① Insert a block gauge (thickness gauge) of thickness 2.7 ± 0.05 mm in the gap between the idling stopper bolt and the bracket.
- ② With the control lever positioned as described in ① above, adjust the dashpot adjusting screw so that the dashpot adjusting screw and the push rod are in contact. Fix the screw using the nut.

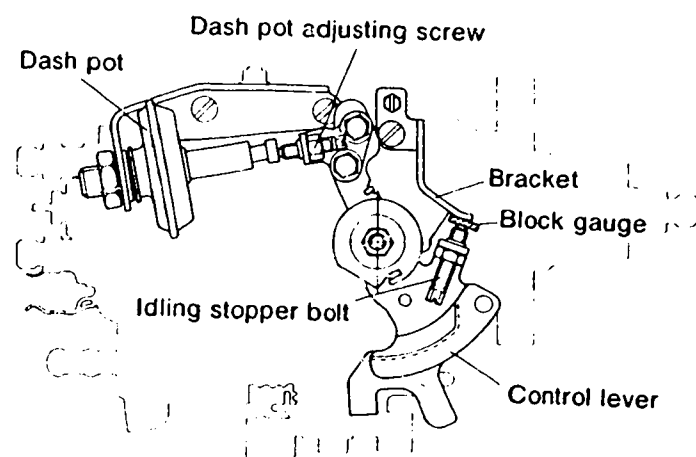

■ ISC (Idle Speed Control) Actuator Installation

1. Hold the control lever in the idling position.
2. Adjust the position of the actuator bracket so that the gap between the control lever and the ISC lever roller is 1.5 ± 0.5 mm, and then fix the bracket in position.

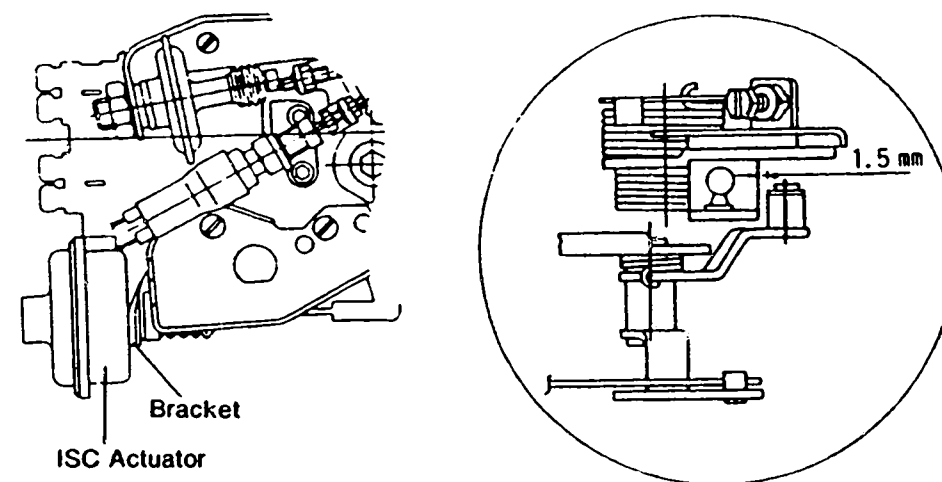

■ Starting Injection Quantity Adjustment

Adjust the starting injection quantity (item 1 / 5) using the adjusting bolt (as shown in the figure at right).

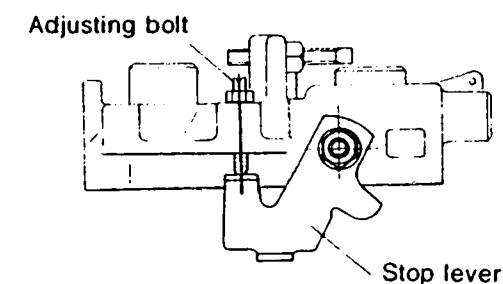

INJ. PUMP CALIBRATION DATA

TEST OIL:
ISO 4113 or
SAE J967d

Distributor-type

ENGINE MODEL : RD28

Injection pump No: 104669-2112 [NP-VE6/9F2500RNP40]

BOSCH No. 9 480 610 267 1/4

DKKC No. 104769-2114

Date: 15. Oct. 1987 [1]

Company: NISSAN

No. 16700 V7204

194769-2114 2/4

Pump rotation : clockwise-viewed from drive side

For Test Condition see
Microfiche No.WP-210(N16)

Pre-stroke : — mm

1. Setting	Pump speed (rpm)	Settings	Charge air press(mmHg)	Difference in delivery(cc)
1-1 Timing device travel	900	1.2 ~ 1.6 (mm)		
1-2 Supply pump pressure	900	3.5 ~ 4.1 (kg/cm ²)		
1-3 Full load delivery without charge air pressure	900	30.9 ~ 31.9 (cc/1,000st)		2.5
Full load delivery with charge air pressure		(cc/1,000st)		
1-4 Idle speed regulation	350	5.8 ~ 8.8 (cc/1,000st)		
1-5 Start	100	40.8 ~ 48.8 (cc/1,000st)		
1-6 Full-load speed regulation	2,600	15.5 ~ 21.5 (cc/1,000st)		
1-7				
1-8				

2. Test Specifications

2-1 Timing device	N = rpm	900	1,200	2,300	
	mm	1.1 ~ 1.7	2.7 ~ 3.5	8.1 ~ 9.0	
2-2 Supply pump	N = rpm	900	1,800	2,500	
	kg/cm ²	3.4 ~ 4.2	5.5 ~ 6.3	7.2 ~ 8.0	
2-3 Overflow delivery	N = rpm	900			
	cc/10s	43.0 ~ 87.0			
2-4 Fuel deliveries					
Speed control lever	Pump speed (rpm)	Fuel delivery (cc/1,000st)	Charge air press(mmHg)	Difference in delivery	
End stop	2,800	Below 5.0			
	2,600	15.0 ~ 22.0			
	2,300	28.0 ~ 32.0			
	900	30.4 ~ 32.4			
	600	29.1 ~ 33.1			
Switch OFF	350	0			
Idle stop	350	5.3 ~ 9.3		1.4	
	500	Below 4.0			
Partial load	900	2.5 ~ 12.5			
2-5 Solenoid	Max.cut-in voltage : 8 V				
	Test voltage : 12~14 V				

3. Dimensions

K	3.2 ~ 3.4	mm
KF	6.54 ~ 6.74	mm
MS	1.7 ~ 1.9	mm
BCS	—	mm

Control lever angle

α	19.0 ~ 27.0	deg
A	8.7 ~ 12.9	mm
β	37.0 ~ 47.0	deg
B	11.5 ~ 15.2	mm
γ	10.5 ~ 11.5	deg
C	5.7 ~ 6.3	mm

W-CSD Adjustment

1) Timer Stroke Adjustment (adjust to the thick line)

- Calculate the timer stroke from Fig. 2 according to the atmospheric temperature at the time of adjustment.
- Adjust using the timer stroke adjusting screw so that the timer stroke is as calculated in Step 1.

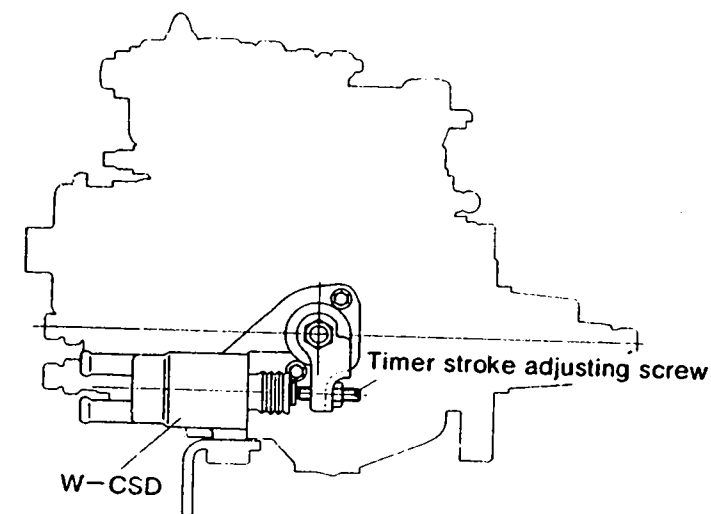

Fig. 1

Formula for calculating Fig. 2

Formula for calculating timer stroke:

$$\text{When } -10 \leq t(^{\circ}\text{C}) \leq 20 \quad T = -0.0367t + 1.284$$

$$\text{When } 20 \leq t(^{\circ}\text{C}) \leq 40 \quad T = -0.0275t + 1.1$$

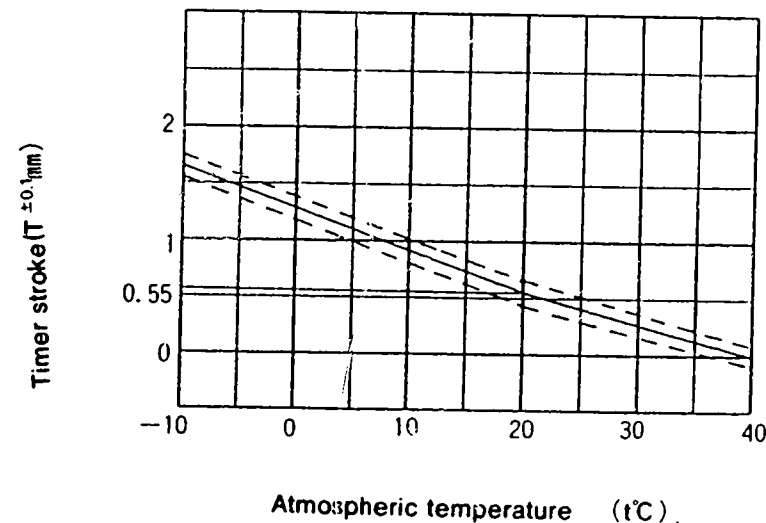
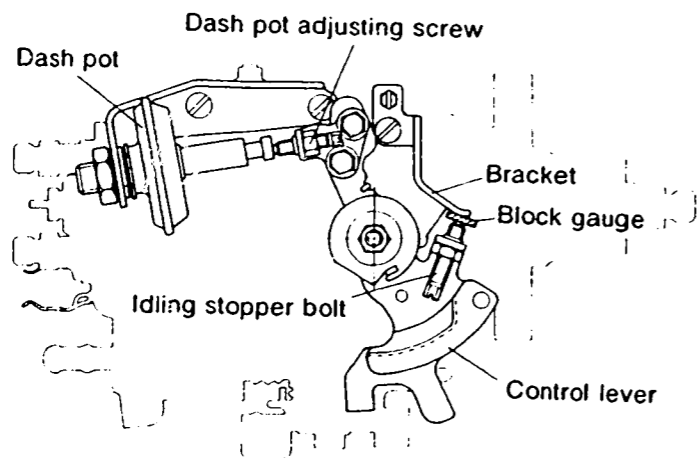

Fig. 2

■ DASH POT ADJUSTMENT

- ① Insert a block gauge (thickness gauge) of thickness 2.7 ± 0.05 mm in the gap between the idling stopper bolt and the bracket.
- ② With the control lever positioned as described in ① above, adjust the dashpot adjusting screw so that the dashpot adjusting screw and the push rod are in contact. Fix the screw using the nut.



■ Starting Injection Quantity Adjustment

Adjust the starting injection quantity (item 1 / 5) using the adjusting bolt (as shown in the figure at right) .

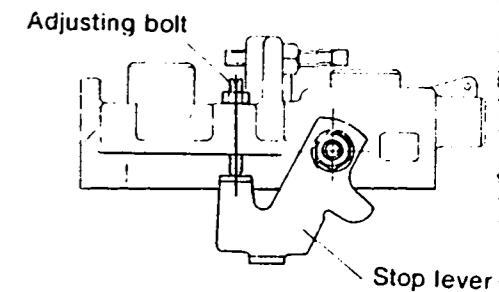

■ ISC (Idle Speed Control) Actuator Installation

1. Hold the control lever in the idling position.
2. Adjust the position of the actuator bracket so that the gap between the control lever and the ISC lever roller is 1.5 ± 0.5 mm, and then fix the bracket in position.

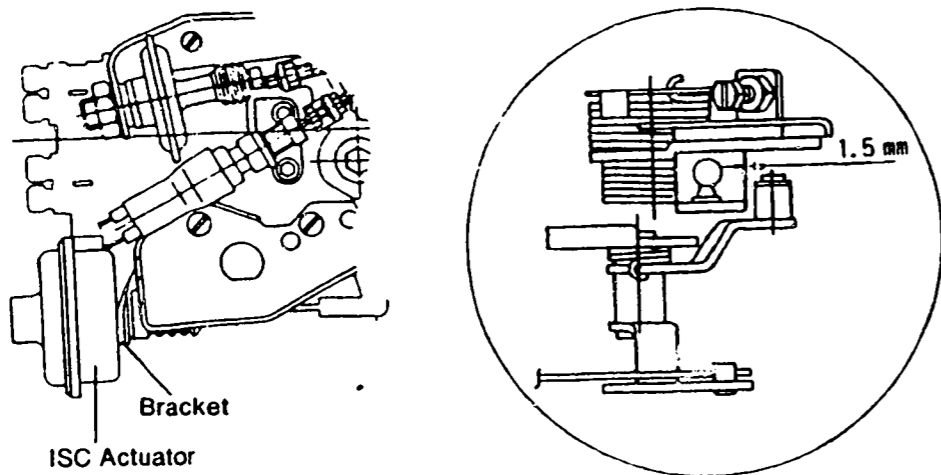

Table of Contents (DKKC No. → BOSCH No.)

DKKC No.	BOSCH No.	Location	DKKC No.	BOSCH No.	Location
101631-9775	9 400 610 068	WP-215 B- 1~B- 2			
101641-9123	9 400 610 063	WP-215 B- 3~B- 5			
101641-9133	9 400 610 089	WP-215 B- 6~B- 8			
101641-9152	9 400 610 070	WP-215 B- 9~B-11			
104740-1141	9 460 610 259	WP-215 B-12			
104740-2061	9 460 610 260	WP-215 B-13~B-14			
104740-4702	9 460 610 261	WP-215 B-15			
104749-0294	9 460 610 262	WP-215 C- 1~C- 2			
104749-0323	9 460 610 263	WP-215 C- 3~C- 4			
104749-0333	9 460 610 264	WP-215 C- 5~C- 6			
104749-2231	9 460 610 265	WP-215 C- 7~C- 8			
104769-2104	9 460 610 266	WP-215 C- 9~C-10			
104769-2114	9 460 610 267	WP-215 C-11~C-12			

Table of Contents (BOSCH No. → DKKC No.)

BOSCH No.	DKKC No.	Location	DKKC No.	BOSCH No.	Location
9 400 610 063	101641-9123	WP-215 B- 3~B- 5			
9 400 610 068	101631-9775	WP-215 B- 1~B- 2			
9 400 610 089	101641-9133	WP-215 B- 6~B- 8			
9 400 610 070	101641-9152	WP-215 B- 9~B-11			
9 460 610 259	104740-1141	WP-215 B-12			
9 460 610 260	104740-2061	WP-215 B-13~B-14			
9 460 610 261	104740-4702	WP-215 B-15			
9 460 610 262	104749-0294	WP-215 C- 1~C- 2			
9 460 610 263	104749-0323	WP-215 C- 3~C- 4			
9 460 610 264	104749-0333	WP-215 C- 5~C- 6			
9 460 610 265	104749-2231	WP-215 C- 7~C- 8			
9 460 610 266	104769-2104	WP-215 C- 9~C-10			
9 460 610 267	104769-2114	WP-215 C-11~C-12			